

PRODUCT CATALOG

LOW VOLTAGE 3-PHASE INDUCTION MOTORS

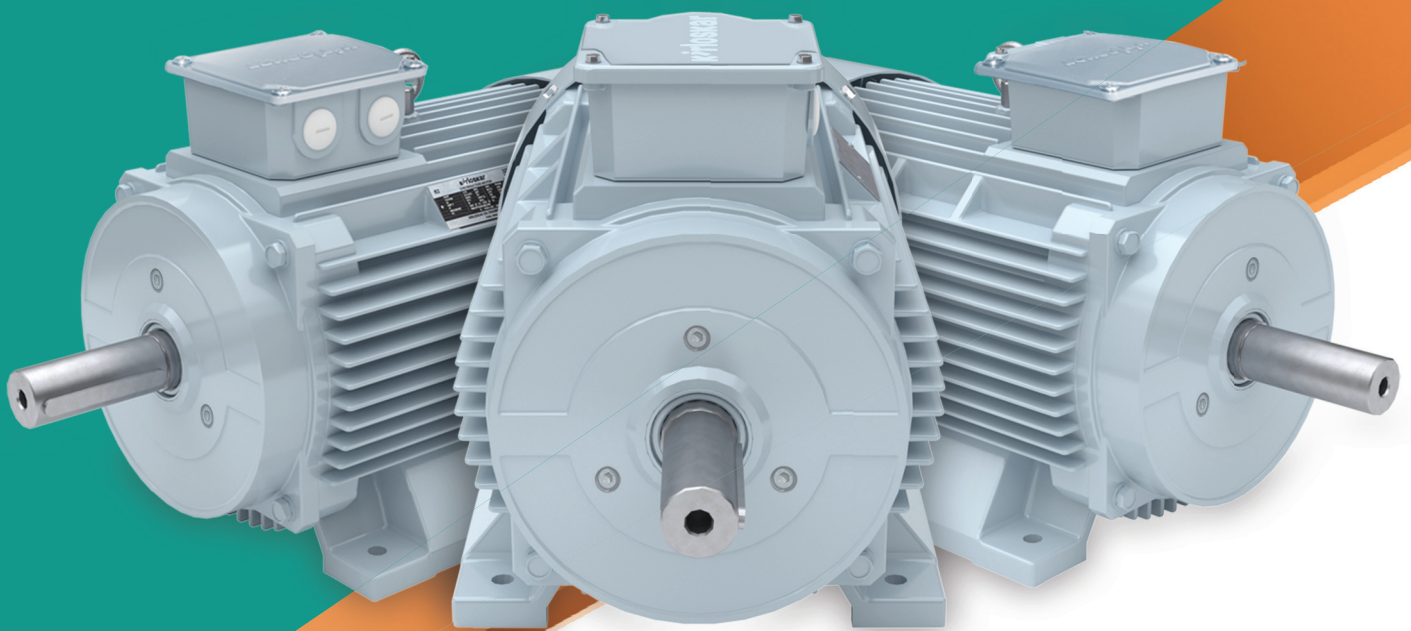

kirloskar
motors

Performance Beyond Expectations

KIRLOSKAR OIL ENGINES LIMITED

A Kirloskar Group Company

Contents:

1	Reference Standards:	1
2	Tolerance on Electrical Performance:	2
3	Standard Specifications for Three Phase Induction Motors-IE2:	3
4	Bearing Details:	4
5	Cable Sizes and Cable Entry:	5
6	Performance Data - IE2 Efficiency Aluminium Series:	6
7	Performance Data - IE2 Efficiency Cast Iron Series:	9
8	Dimensional Drawing(Aluminium Series):	
	➤ KM63 & KM71	13
	➤ KM80 to KM112	15
9	Dimensional Drawing(Cast Iron Series):	
	➤ KM80 to KM112	17
	➤ KM160 to KM200	20
	➤ KM225 to KM280	22
10	Terminal Box Arrangement:	
	➤ KM63 & KM71	25
	➤ KM80 to KM132	26
	➤ KM160	27
	➤ KM180 & KM200	28
	➤ KM225 & KM250	29
	➤ KM280	30
11	Exploded View:	31
12	Product Code Guide:	32

Reference Standards:

All Kirloskar Motors shall comply with the latest International and Indian Standards.

These are as under:

List of International Standards:

1. IEC60034-1: Rotating Electrical Machines, Part-1; Rating and Performance.
2. IEC60034-2-1 Standard Methods for Determining Losses and Efficiency.
3. IEC60034-5: Degree of Protection.
4. IEC60034-6: Method of Cooling.
5. IEC60034-9: Noise Limits.
6. IEC60034-14: Mechanical Vibrations Measurement, Evaluation and Limits of Severity.
7. IEC60034-30: Efficiency Classes of Single Speed Three Phase Squirrel Cage Induction Motors.
8. IEC60072-1: Dimensions and Output Ratings of Electrical Machines.

List of Indian Standards:

1. IS1231: Dimensions of Three Phase Induction Motors- Foot Mounted.
2. IS2223: Dimensions of Flange Mounted AC Induction Motors.
3. IS2253: Designations of Types of Construction and Mounting Arrangements for Rotating Electrical Machines.
4. IS4029: Guide for Testing Three Phase Induction Motors.
5. IS4691: Degree of Protection Provided by Enclosures for Rotating Electrical Machinery.
6. IS6362: Designation of Method of Cooling for Rotating Electrical Machines.
7. IS7538: Three Phase Squirrel Cage Induction Motors for Centrifugal Pumps for Agricultural Applications.
8. IS12065: Permissible Limits of Noise Levels for Rotating Electrical Machines.
9. IS12075: Mechanical Vibrations of Rotating Electrical Machines; Measurements, Evaluations and Limits of Vibration Severity.
10. IS12615: Efficiency Classes and Performance Specification.
11. IS15999: Rotating Electrical Machines (Part 1 & 2)
12. IS8151: Single Speed Three Phase Induction Motors for Lifts.

Tolerance on Electrical Performance:

As per IEC 60034-1 or IS 15999-1, the following tolerances are permitted:

- Efficiency η at

kW \leq 150 kW: -15% of $(1 - \eta)$

kW $>$ 150 kW: -10% of $(1 - \eta)$

Where η is a efficiency mentioned in decimals.

- Power factor = $-1/6 (1 - \cos\phi)$
Minimum absolute value: 0.02
Maximum absolute value: 0.07
- $P_N < 1$ kW : $\pm 30\%$ of the slip
- $P_N > 1$ kW : $\pm 20\%$ of the slip
- Locked-rotor Current / Starting Current / SCC: +20% of Full Load Current (FLC)
- Locked-rotor Torque / Starting Torque / STT: -15% to +25 % of indicated value.
- Breakdown Torque / Pull out Torque / POT: -10% of indicated value.
- Moment of Inertia (or GD^2) $\pm 10\%$ of the value.

Voltage and Frequency Variation:

- As per IS 12615 : 2018, motors shall be capable of delivering rated output with:
 - a. Terminal voltage differing from its rated value by not more than $\pm 10\%$
 - b. Frequency differing from its rated value by not more than $\pm 5\%$
 - c. Combined variation - The sum of absolute percent variation of (a) and (b) not exceeding 10%.

In the case of continuous operation at the extreme voltage limits specified at (a) and (b), the temperature rise limits of the winding specified in IS 15999 (Part 1)/IEC 60034-1 shall not exceed by more than 20 K.

In such cases, motor may be designed with higher class of insulation.

Motors operated under the extreme conditions of voltage and/or frequency specified in (a) and (b), the performance values given in the selection tables may not necessarily comply with IS 12615

Efficiency and Power Factor:

The nominal efficiency (η) and the power factor ($\cos\phi$) for motors is listed in the tables.

Efficiency and other performance figures are committed at rated voltage and frequency.

Rated Speed and Direction of Rotation:

The rated speeds are applicable for the rated data. The synchronous speed changes proportionally with the line frequency. The motors are suitable for bi-directional rotation.

Default direction of rotation is Clockwise from DE when L1,L2 and L3 are connected to U1,V1 and W1 respectively. Counter clockwise rotation is achieved by interchanging any of the two phases.

Rated Torque:

The rated torque in kg-m delivered at the motor shaft is

$$T = (974 \times P)/N$$

Where P is power in kW & N is Full Load Speed in RPM.

All motors are with VPI treatment

Standard Specifications for Three Phase Induction Motors-IE2:

Unless specified, all Kirloskar Motors shall comply with the following specifications:

Sr No	Parameters	Details
1	Power In kW	0.12 to 90
2	Pole	2P, 4P, 6P*, 8P*
3	Frame Sizes	KM63 to KM280M
4	Operating Voltage	415V +/- 10%
5	Frequency	50 Hz +/- 5%
6	Combined Variation	10% (Absolute)
7	Enclosure	Totally Enclosed Fan Cooled (TEFC)
8	Degree of Protection	IP55
9	Efficiency Level	IE2 as per IS12615:2018
10	Frame Dimensions	As per IS 1231 / IS 2223 / IEC 60072
11	Insulation Class	Class F with Temperature Rise Limited to Class B
12	Design Ambient Temperature	50°C
13	Temperature Rise	70°C (By Resistance Method)
14	Altitude	≤ 1000 Meters from Mean Sea Level
15	Relative Humidity	Upto 95%
16	Atmospheric Conditions	Tropical Corrosive
17	Duty	S1-Continuous
18	Type of Rotor	Squirrel Cage
19	Dynamic Balancing	Grade 2.5 as per ISO 1940
20	Motor Mounting	IMB3 , IMB5* , IMB35* , IMV1* , IMB14** & IMB34**
21	Mechanical Dimensions	As per GA Drawings
22	General Enclosure Material	Frames 63 to 112 : Aluminium body (detachable feet) & Endshields Frames 80 to 280 : Cast Iron body & Endshields
23	Type of Cooling	Externally Fan Cooled- IC411 as per IS6362
24	Position of Terminal Box	TOP
25	Type of Starting	For Motors < 2.20 KW : Direct On-Line For Motors ≥ 2.20 KW: Direct On-Line / Star Delta.
26	Connection / No. of Leads	Star connection / 6 lead for 63 to 100 frame and < 2.2kW Delta connection / 6 lead for 100 to 280 frame and ≥ 2.2 kW
27	Terminal Arrangement	Stud Type
28	Type of Coupling	Direct-Flexible
29	Direction of Rotation	Bi-Directional
30	Bearings	Deep Groove Anti-Friction Ball Bearings
31	Greasing Arrangement	Greased for Life (L-10, 40000 Hrs.)
32	Bearing Seals	Oil Seals
33	Vibration Levels	IS12075
34	Noise Levels	IS12065
35	Paint Shade	RAL7046 (Tele-grey)
36	Electrical Performance	As per IS12615:2018 and performance data
37	VFD Suitability	Motors are suitable for VFD operation for variable torque application 10 - 100% Speed Range. Temperature rise limited to Class 'F' rise on VFD.

*On Request

** For 63 to 132 Frame

Bearings Details:

All Kirloskar Motors are provided with appropriately sized Deep Groove Ball Bearings.

Deep Groove Ball Bearings are the most popular and widely used bearing types. These have low friction and are optimized for low noise and low vibration which enables high rotational speeds.

The Deep Groove accommodate radial and axial loads in both directions, are easy to mount, and require less maintenance than other bearing types, being sealed for life.

The frame wise bearing sizes are as under:

Aluminium Motors Bearing Reference:

Sr. No.	Frame	DE Bearing	NDE Bearing
1	KM63	6202ZZ	6202ZZ
2	KM71	6203ZZ	6203ZZ
3	KM80	6204ZZ	6204ZZ
4	KM90S	6205ZZ	6205ZZ
5	KM90L	6205ZZ	6205ZZ
6	KM100L	6206ZZ	6206ZZ
7	KM112M	6306ZZ	6306ZZ

Cast Iron Motors Bearing Reference:

Sr. No.	Frame	DE Bearing	NDE Bearing
1	KM80	6204ZZ	6203ZZ
2	KM90S	6205ZZ	6204ZZ
3	KM90L	6205ZZ	6204ZZ
4	KM100L	6206ZZ	6205ZZ
5	KM112M	6206ZZ	6205ZZ
6	KM132S	6308ZZ	6208ZZ
7	KM132M	6308ZZ	6208ZZ
8	KM160M	6309ZZ	6309ZZ
9	KM160L	6309ZZ	6309ZZ
10	KM180M	6310ZZ	6310ZZ
11	KM180L	6310ZZ	6310ZZ
12	KM200L	6312ZZ	6312ZZ
13	KM225S	6313ZZ C3	6312ZZ C3
14	KM225M	6313ZZ C3	6312ZZ C3
15	KM250M	6315C3	6314C3
16	KM280S	6317C3	6316C3
17	KM280M	6317C3	6316C3

All motors are with VPI treatment

Cable Sizes and Cable Entry:

All Kirloskar Motors are provided with appropriately sized terminal boxes mounted on TOP for easy access.

The frame wise cable sizes as per Kirloskar standard are as under:

Frame	Cable Size	Cable Entry
KM63	1X3CX4 mm ²	M16 X 1.5 – 1 No.
KM71	1X3CX4 mm ²	M16 X 1.5 – 1 No.
KM80	1X3CX4 mm ²	M20 X 1.5 – 1 No.
KM90S	1X3CX4 mm ²	M20 X 1.5 – 1 No.
KM90L	1X3CX4 mm ²	M20 X 1.5 – 1 No.
KM100L	2X3CX6 mm ²	M20 X 1.5 – 2 Nos.
KM112M	2X3CX10 mm ²	M25 X 1.5 – 2 Nos.
KM132S	2X3CX10 mm ²	M25 X 1.5 – 2 Nos.
KM132M	2X3CX10 mm ²	M25 X 1.5 – 2 Nos.
KM160M	2X3CX25 mm ²	M25 X 1.5 – 2 Nos.
KM160L	2X3CX25 mm ²	M25 X 1.5 – 2 Nos.
KM180M	2X3CX50 mm ²	M40 X 1.5 – 2 Nos.
KM180L	2X3CX50 mm ²	M40 X 1.5 – 2 Nos.
KM200L	2X3CX70 mm ²	M40 X 1.5 – 2 Nos.
KM225S	2X3CX120 mm ²	M50 X 1.5 – 2 Nos.
KM225M	2X3CX120 mm ²	M50 X 1.5 – 2 Nos.
KM250M	2X3CX120 mm ²	M50 X 1.5 – 2 Nos.
KM280S	2X3CX185 mm ²	M63 X 1.5 – 2 Nos.
KM280M	2X3CX185 mm ²	M63 X 1.5 – 2 Nos.

Performance Data - IE2 Efficiency Aluminium Series:

Aluminium series motors are with detachable feet.
All motors are with VPI treatment.

POLE	2 (3000RPM)		AMBIENT	50°C		INSULATION CLASS		F								
	VOLTAGE	415 ±10%		DUTY	S1	THERMAL CLASS	B									
FREQUENCY	50Hz ±5% <td colspan="6">EFFICIENCY CLASS AS PER IEC 60034-30-1:2014, IS 12615:2018</td>		EFFICIENCY CLASS AS PER IEC 60034-30-1:2014, IS 12615:2018													
COMBINED VARIATION	10%															
Product Code	Output	Frame Size	Rated Speed	FLC	FLT	% Efficiency			Power Factor			Starting Current	Starting Torque	Pull Out Torque	GD ²	Net Weight
						FL	3/4 FL	1/2 FL	FL	3/4 FL	1/2 FL					
KM2.0T18.AEA.B03.TSS	0.18	KM63	2880	0.71	0.06	60.4	60.4	59.0	0.58	0.49	0.42	600	200	250	0.0007	5.92
KM2.0T25.AEA.B03.TSS	0.25	KM63	2840	0.81	0.09	64.8	64.8	63.0	0.66	0.56	0.43	600	200	250	0.0008	5.92
KM2.0T37.AFA.B03.TSS	0.37	KM71	2875	0.97	0.13	69.5	69.5	67.0	0.76	0.69	0.58	600	200	250	0.0019	7.24
KM2.0T55.AFA.B03.TSS	0.55	KM71	2895	1.36	0.19	74.1	74.1	73.0	0.76	0.67	0.55	600	200	250	0.0021	7.50
KM2.0T75.AGA.B03.TSS	0.75	KM80	2830	1.62	0.26	77.4	77.4	75.0	0.83	0.78	0.72	600	250	300	0.0034	9.90
KM2.1T10.AGA.B03.TSS	1.1	KM80	2860	2.40	0.37	79.6	79.6	77.0	0.80	0.73	0.61	600	200	250	0.0036	10.20
KM2.1T50.AHA.B03.TSS	1.5	KM90S	2840	3.10	0.51	81.3	81.3	80.0	0.83	0.78	0.66	650	200	250	0.0066	16.20
KM2.2T20.AHA.B03.TSS	2.2	KM90L	2890	4.20	0.74	83.2	83.2	81.0	0.88	0.85	0.76	650	200	250	0.0081	18.00
KM2.3T70.AIA.B03.TSS	3.7 *	KM100L	2875	7.40	1.25	85.5	84.5	83.0	0.82	0.76	0.65	600	225	275	0.0151	23.60
KM2.4T00.AJA.B03.TSS	4.0 #	KM112M	2875	7.40	1.35	85.8	85.0	83.0	0.88	0.80	0.74	600	200	250	0.0243	28.00

* Rating suitable for 80 °C temperature rise (by resistance method)

Rating suitable for 95 °C temperature rise (by resistance method)

Performance Data - IE2 Efficiency Aluminium Series:

Aluminium series motors are with detachable feet.
All motors are with VPI treatment.

POLE	4 (1500RPM)		AMBIENT		50°C		INSULATION CLASS		F							
	VOLTAGE	415 ±10%	DUTY	S1	FL	3/4 FL	1/2 FL	FL	3/4 FL	1/2 FL						
FREQUENCY	50Hz ±5%	EFFICIENCY CLASS AS PER IEC 60034-30-1:2014, IS 12615:2018														
COMBINED VARIATION	10%															
Product Code	Output	Frame Size	Rated Speed	FLC	FLT	% Efficiency			Power Factor		Starting Current	Starting Torque	Pull Out Torque	GD ²	Net Weight	
	kW		RPM	A	Kg-m	FL	3/4 FL	1/2 FL	FL	3/4 FL	1/2 FL	% FLC	% FLT	% FLT	kg-m ²	kg
KM2.0T12.BEA.B03.TSS	0.12	KM63	1320	0.40	0.09	59.1	59.1	55.0	0.70	0.66	0.60	550	200	250	0.0009	5.00
KM2.0T18.BEA.B03.TSS	0.18	KM63	1345	0.59	0.13	64.7	64.7	62.0	0.66	0.57	0.46	550	225	275	0.0011	5.00
KM2.0T25.BFA.B03.TSS	0.25	KM71	1400	0.69	0.17	68.5	67.5	63.0	0.74	0.64	0.58	550	225	275	0.0029	6.80
KM2.0T37.BFA.B03.TSS	0.37	KM71	1400	1.00	0.26	72.7	72.7	66.0	0.71	0.61	0.49	550	200	250	0.0031	6.80
KM2.0T55.BGA.B03.TSS	0.55	KM80	1435	1.65	0.37	77.1	76.3	71.4	0.60	0.50	0.38	600	200	250	0.0054	9.70
KM2.0T75.BGA.B03.TSS	0.75	KM80	1420	1.90	0.51	79.6	79.6	74.0	0.69	0.60	0.46	550	200	250	0.0057	9.90
KM2.1T10.BHA.B03.TSS	1.1	KM90S	1420	2.50	0.75	81.4	80.4	79.0	0.76	0.70	0.60	600	200	250	0.0110	17.00
KM2.1T50.BHA.B03.TSS	1.5	KM90L	1420	3.45	1.03	82.8	82.8	80.5	0.74	0.67	0.53	600	275	325	0.0135	18.50
KM2.2T20.BIA.B03.TSS	2.2	KM100L	1435	4.84	1.49	84.3	84.3	82.5	0.75	0.71	0.56	600	275	325	0.0236	23.00
KM2.3T70.BJA.B03.TSS	3.7	KM112M	1450	8.0	2.49	86.3	86.0	84.0	0.75	0.71	0.59	600	200	250	0.0441	30.00
KM2.4T00.BJA.B03.TSS	4.0 *	KM112M	1450	8.4	2.69	86.6	85.0	84.0	0.77	0.74	0.61	600	200	250	0.0458	31.50

* Rating suitable for 80 °C temperature rise (by resistance method)

Performance Data - IE2 Efficiency Aluminium Series:

Aluminium series motors are with detachable feet.
All motors are with VPI treatment.

Product Code	Output kW	Frame Size	Rated Speed RPM	FLC A	FLT Kg-m	% Efficiency			Power Factor			Starting Current % FLC	Starting Torque % FLT	Pull Out Torque % FLT	GD ² kg-m ²	Net Weight kg
						FL	3/4 FL	1/2 FL	FL	3/4 FL	1/2 FL					
KM2.0T37.CGA.B03.TSS	0.37	KM80	910	1.12	0.39	67.6	67.6	65.0	0.68	0.60	0.45	500	180	225	0.0110	9.5
KM2.0T55.CGA.B03.TSS	0.55	KM80	925	1.74	0.57	73.1	73.1	70.0	0.60	0.50	0.44	500	180	225	0.0115	10.5
KM2.0T75.CHA.B03.TSS	0.75	KM90S	940	2.10	0.77	75.9	75.9	72.0	0.66	0.55	0.45	600	200	250	0.0177	15.7
KM2.1T10.CHA.B03.TSS	1.1	KM90L	930	2.84	1.15	78.1	78.1	74.0	0.69	0.60	0.45	600	200	250	0.0217	17.7
KM2.1T50.CIA.B03.TSS	1.5	KM100L	940	3.68	1.55	79.8	79.8	78.0	0.71	0.62	0.50	600	180	225	0.0407	23
KM2.2T20.CJA.B03.TSS	2.2	KM112M	955	5.42	2.24	81.8	81.8	78.0	0.69	0.62	0.50	600	180	225	0.0688	30

POLE 6 (1000RPM) AMBIENT 50°C INSULATION CLASS F
 VOLTAGE 415 ±10% DUTY S1 THERMAL CLASS B
 FREQUENCY 50Hz ±5% EFFICIENCY CLASS AS PER IEC 60034-30-1:2014, IS 12615:2018
 COMBINED VARIATION 10%

Performance Data - IE2 Efficiency Cast Iron Series:

Motors in frames KM180 to KM280 are provided with 3 no. PTC 130 as a standard feature.

POLE	2 (3000RPM)	AMBIENT	50°C	INSULATION CLASS		F	Starting Current	Starting Torque	Pull Out Torque	GD ²	Net Weight		
				FLC	FLT							% Efficiency	Power Factor
VOLTAGE	415 ±10%	DUTY	S1	FL	3/4 FL	1/2 FL	% FLC	% FLT	% FLT	kg-m ²	kg		
FREQUENCY	50Hz ±5%												
COMBINED VARIATION	10%												
Product Code	Output	Frame Size	Rated Speed	FLC	FLT	% Efficiency	Power Factor	Starting Current	Starting Torque	Pull Out Torque	GD ²	Net Weight	
	kW		RPM	A	kg-m	FL	3/4 FL	1/2 FL	% FLC	% FLT	kg-m ²	kg	
KM2.0T75.AGC.B03.TSS	0.75	KM80	2820	1.64	0.26	77.4	76.5	73.5	0.82	0.74	0.62	0.0021	10
KM2.1T10.AGC.B03.TSS	1.1	KM80	2830	2.34	0.38	79.6	79.6	75.5	0.82	0.75	0.63	0.0023	11
KM2.1T50.AHC.B03.TSS	1.5	KM90S	2840	3.13	0.51	81.3	81.3	80.0	0.82	0.77	0.66	0.0064	25
KM2.2T20.AHC.B03.TSS	2.2	KM90L	2830	4.33	0.76	83.2	83.2	82.5	0.85	0.80	0.72	0.0078	28
KM2.3T70.AIC.B03.TSS	3.7 *	KM100L	2865	7.30	1.26	85.5	85.5	83.0	0.83	0.78	0.68	0.0147	36
KM2.5T50.AKC.B03.TSS	5.5	KM132S	2930	9.8	1.83	87.0	87.0	84.5	0.90	0.88	0.84	0.062	72
KM2.7T50.AKC.B03.TSS	7.5	KM132S	2930	13.2	2.49	88.1	87.7	86.0	0.90	0.88	0.84	0.075	75
KM2.9T30.AKC.B03.TSS	9.3 *	KM132S	2930	16.2	3.09	88.9	88.5	86.5	0.90	0.88	0.84	0.080	79
KM2.9T30.ALC.B03.TSS	9.3	KM160M	2920	17	3.10	88.9	87.5	86.5	0.88	0.85	0.80	0.14	105
KM2.11T0.ALC.B03.TSS	11	KM160M	2940	19	3.64	89.4	89.4	87.0	0.88	0.85	0.77	0.19	112
KM2.15T0.ALC.B03.TSS	15	KM160M	2940	26	4.97	90.3	90.0	88.0	0.88	0.86	0.80	0.23	121
KM2.18T5.ALC.B03.TSS	18.5	KM160L	2940	32	6.13	90.9	90.5	88.0	0.88	0.85	0.80	0.25	135
KM2.22T0.AMC.B03.TSS	22	KM180M	2960	38	7.23	91.3	91.0	88.8	0.89	0.86	0.82	0.47	185
KM2.30T0.ANC.B03.TSS	30	KM200L	2950	51	9.90	92.0	91.5	90.0	0.89	0.86	0.80	0.65	236
KM2.37T0.ANC.B03.TSS	37	KM200L	2950	63	12.21	92.5	92.5	91.0	0.89	0.86	0.80	0.74	240
KM2.45T0.AQC.B03.TSS	45	KM225M	2950	74	14.86	92.9	92.9	91.5	0.91	0.89	0.85	1.39	320
KM2.55T0.ARC.B03.TSS	55	KM250M	2965	90	18.07	93.2	92.5	91.0	0.91	0.89	0.85	1.84	390
KM2.75T0.ASC.B03.TSS	75	KM280S	2970	121	24.60	93.8	92.5	90.0	0.92	0.90	0.86	3.76	680
KM2.90T0.ATC.B03.TSS	90	KM280M	2970	145	29.52	94.1	93.8	91.0	0.92	0.90	0.86	4.57	720

* Rating suitable for 80 °C temperature rise (by resistance method)

Performance Data - IE2 Efficiency Cast Iron Series:

All motors are with VPI treatment

POLE	4 (1500RPM)		AMBIENT		50°C		INSULATION CLASS			F						
	VOLTAGE	415 ±10%	DUTY	S1	FL	3/4 FL	1/2 FL	FL	3/4 FL	1/2 FL	FL					
FREQUENCY	50Hz ±5%		EFFICIENCY CLASS AS PER IEC 60034-30-1:2014, IS 12615:2018		S1		THERMAL CLASS		B							
COMBINED VARIATION	10%															
Product Code	Output	Frame Size	Rated Speed	FLC	FLT	% Efficiency		Power Factor			Starting Current	Starting Torque	Pull Out Torque	GD ²	Net Weight	
	kW		RPM	A	Kg-m	FL	3/4 FL	1/2 FL	FL	3/4 FL	1/2 FL	% FLC	% FLT	% FLT	kg-m ²	kg
KM2.0T55.BGC.B03.TSS	0.55	KM80	1435	1.63	0.37	77.1	76.3	71.4	0.61	0.51	0.38	600	250	300	0.0057	13
KM2.0T75.BGC.B03.TSS	0.75	KM80	1410	1.85	0.52	79.6	79.6	74.0	0.71	0.63	0.51	500	200	250	0.0060	14
KM2.1T10.BHC.B03.TSS	1.1	KM90S	1440	2.58	0.74	81.4	81.4	79.0	0.73	0.65	0.52	600	250	300	0.0140	25
KM2.1T50.BHC.B03.TSS	1.5	KM90L	1430	3.23	1.02	82.8	82.8	80.5	0.78	0.72	0.60	600	275	325	0.0150	28
KM2.2T20.BIC.B03.TSS	2.2	KM100L	1440	4.84	1.49	84.3	84.3	82.5	0.75	0.67	0.55	650	200	250	0.0280	36
KM2.3T70.BIC.B03.TSS	3.7	KM112M	1440	7.27	2.50	86.3	86.3	85.0	0.82	0.78	0.67	650	225	275	0.051	45
KM2.5T50.BKC.B03.TSS	5.5	KM132S	1450	10.7	3.69	87.7	87.7	86.0	0.82	0.78	0.68	650	250	300	0.130	72
KM2.7T50.BKC.B03.TSS	7.5	KM132M	1455	14.2	5.02	88.7	88.7	87.0	0.83	0.80	0.70	650	250	300	0.152	80
KM2.9T30.BKC.B03.TSS	9.3	KM132M	1445	16.7	6.27	89.3	89.0	87.5	0.87	0.84	0.80	600	200	250	0.155	82
KM2.9T30.BLC.B03.TSS	9.3	KM160M	1450	18	6.25	89.3	89.0	87.0	0.81	0.76	0.65	600	180	225	0.26	107
KM2.11T0.BLC.B03.TSS	11	KM160M	1450	21	7.39	89.8	89.8	88.5	0.83	0.80	0.76	650	175	225	0.29	110
KM2.15T0.BLC.B03.TSS	15	KM160L	1455	27	10.04	90.6	90.6	89.5	0.84	0.82	0.76	650	175	225	0.38	133
KM2.18T5.BMC.B03.TSS	18.5	KM180M	1475	33	12.22	91.2	91.2	89.5	0.86	0.84	0.77	650	180	230	0.95	185
KM2.22T0.BMC.B03.TSS	22	KM180L	1475	38	14.53	91.6	91.6	89.8	0.87	0.85	0.78	650	180	230	1.04	190
KM2.30T0.BNC.B03.TSS	30	KM200L	1475	53	19.81	92.3	92.0	90.0	0.85	0.82	0.72	700	200	250	1.04	236
KM2.37T0.BPC.B03.TSS	37	KM225S	1470	62	24.52	92.7	92.7	91.5	0.89	0.87	0.84	650	225	275	1.94	330
KM2.45T0.BQC.B03.TSS	45	KM225M	1470	76	29.81	93.1	93.1	92.0	0.88	0.86	0.82	700	200	275	2.21	350
KM2.55T0.BRC.B03.TSS	55	KM250M	1475	94	36.32	93.5	93.5	92.0	0.87	0.85	0.80	700	175	225	3.90	450
KM2.75T0.BSC.B03.TSS	75	KM280S	1480	128	49.36	94.0	93.5	92.5	0.87	0.85	0.80	700	160	225	6.79	710
KM2.90T0.BTC.B03.TSS	90	KM280M	1480	151	59.23	94.2	94.0	93.0	0.88	0.85	0.80	700	160	225	7.96	750

Performance Data - IE2 Efficiency Cast Iron Series:

Motors in frames KM180 to KM280 are provided with 3 no. PTC 130 as a standard feature.

POLE	6 (1000RPM)		AMBIENT		50°C		INSULATION CLASS		F							
	VOLTAGE	415 ±10%	DUTY	S1	FL	3/4 FL	1/2 FL	FL	3/4 FL	1/2 FL						
FREQUENCY	50Hz ±5%		EFFICIENCY CLASS AS PER IEC 60034-30-1:2014, IS 12615:2018		S1		THERMAL CLASS		B							
COMBINED VARIATION	10%															
Product Code	Output	Frame Size	Rated Speed	FLC	FLT	% Efficiency		Power Factor		Starting Current	Starting Torque	Pull Out Torque	GD ²	Net Weight		
	kW		RPM	A	Kg-m	FL	3/4 FL	1/2 FL	FL	3/4 FL	1/2 FL	% FLC	% FLT	% FLT	kg-m ²	kg
KM2.0T75.CHC.B03.TSS	0.75	KM90S	930	2.00	0.79	75.9	75.9	72.0	0.70	0.62	0.50	500	200	250	0.0210	28
KM2.1T10.CHC.B03.TSS	1.1	KM90L	930	2.90	1.15	78.1	78.1	74.0	0.68	0.62	0.51	500	200	250	0.0230	29
KM2.1T50.CIC.B03.TSS	1.5	KM100L	950	3.85	1.54	79.8	77.0	73.0	0.68	0.60	0.46	500	200	250	0.0460	32
KM2.2T20.CJC.B03.TSS	2.2	KM112M	955	5.05	2.24	81.8	81.8	79.8	0.74	0.66	0.55	550	210	260	0.079	43
KM2.3T70.CKC.B03.TSS	3.7	KM132S	970	8.7	3.72	84.3	84.3	83.5	0.70	0.62	0.50	600	200	250	0.181	68
KM2.5T50.CKC.B03.TSS	5.5	KM132M	960	12.4	5.58	86.0	86.0	85.0	0.72	0.65	0.52	550	200	250	0.207	76
KM2.7T50.CLC.B03.TSS	7.5	KM160M	960	14	7.61	87.2	86.5	85.0	0.83	0.80	0.70	600	175	250	0.41	116
KM2.9T30.CLC.B03.TSS	9.3	KM160L	960	18	9.43	88.1	88.1	87.0	0.83	0.80	0.70	600	170	250	0.49	126
KM2.11T0.CLC.B03.TSS	11	KM160L	970	22	11.05	88.7	88.7	87.0	0.78	0.73	0.60	600	200	250	0.70	144
KM2.15T0.CMC.B03.TSS	15	KM180L	970	29	15.06	89.7	89.7	87.7	0.80	0.75	0.65	600	200	250	0.94	190
KM2.18T5.CNC.B03.TSS	18.5	KM200L	970	33	18.58	90.4	90.4	89.0	0.85	0.81	0.73	600	200	275	1.54	230
KM2.22T0.CNC.B03.TSS	22	KM200L	970	40	22.09	90.9	90.9	89.0	0.85	0.81	0.74	600	200	275	1.74	244

Performance Data - IE2 Efficiency Cast Iron Series:

All motors are with VPI treatment

Product Code	Output kW	Frame Size	Rated Speed RPM	FLC A	FLT Kg-m	% Efficiency			Power Factor			Starting Current % FLC	Starting Torque % FLT	Pull Out Torque % FLT	GD ² kg-m ²	Net Weight kg
						FL	3/4 FL	1/2 FL	FL	3/4 FL	1/2 FL					
KM2.0T37.DHC.B03.TSS	0.37	KM90S	700	1.58	0.51	56.1	56.1	54.0	0.58	0.49	0.40	500	175	200	0.0217	25
KM2.0T55.DHC.B03.TSS	0.55	KM90L	680	1.93	0.79	61.7	61.7	60.5	0.64	0.54	0.43	500	160	200	0.0223	27
KM2.0T75.DIC.B03.TSS	0.75	KM100L	700	2.46	1.04	66.2	66.2	63.0	0.64	0.55	0.40	500	150	175	0.0373	32
KM2.1T10.DIC.B03.TSS	1.1	KM100L	700	3.43	1.53	70.8	70.8	68.0	0.63	0.50	0.38	500	200	225	0.0382	32
KM2.1T50.DIC.B03.TSS	1.5	KM112M	710	4.47	2.06	74.1	74.1	73.0	0.63	0.50	0.40	500	200	225	0.066	43
KM2.2T20.DKC.B03.TSS	2.2	KM132S	710	5.12	3.02	77.6	77.0	74.0	0.77	0.70	0.60	600	140	175	0.151	68

POLE 8 (750 RPM) AMBIENT 50°C INSULATION CLASS F
 VOLTAGE 415 ±10% DUTY S1 THERMAL CLASS B
 FREQUENCY 50Hz ±5% EFFICIENCY CLASS AS PER IEC 60034-30-1:2014, IS 12615:2018
 COMBINED VARIATION 10%

Dimensional Drawing For TEFC, Foot Mounted (B3) Motors: Frames: KM63 & KM71 (Aluminium)

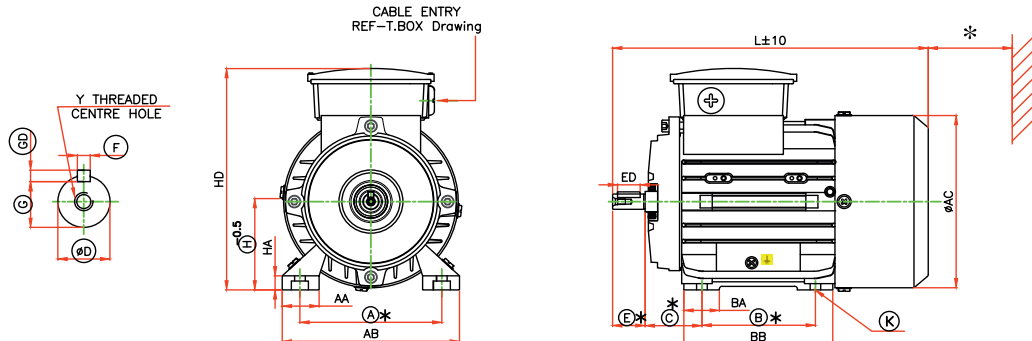

ALL DIMENSIONS ARE IN mm
RINGED DIMENSIONS ARE AS PER IS:1231/IEC:60072-1
*TOLERANCES ON MANDATORY DIMENSIONS ARE AS PER IS:1231/IEC:60072

FRAME	FOOT FIXING							OVER ALL					SHAFT							
	A	B	C	H TOL.	AA	AB	BA	BB	K	AC	L	HD	HA	D TOL.	E	ED	F TOL.	GD TOL.	G	Y
KM63	100	80	40	63/62.5	26	125	25	105	12.5X7.5	123	220	158	10	11.008/10.997	23	16	4/3.97	4/3.97	8.5/8.4	M4X12
KM71	112	90	45	71/70.5	28	140	25	108	12.5X7.5	140	250	178	9	14.008/13.997	30	22	5/4.97	5/4.97	11.0/10.9	M5X12

Dimensional Drawing For TEFC, Flange Mounted (B5) Motors: Frames: KM63 & KM71 (Aluminium)

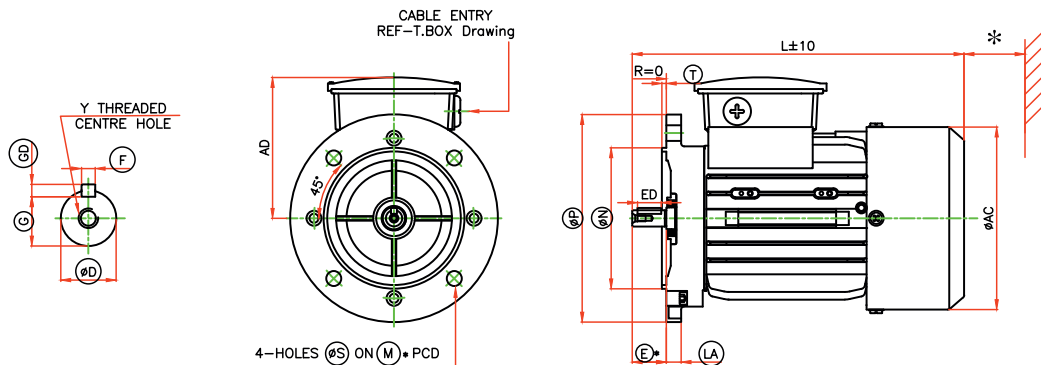

ALL DIMENSIONS ARE IN mm
RINGED DIMENSIONS ARE AS PER IS:2223/IEC:60072-1
*TOLERANCES ON MANDATORY DIMENSIONS ARE AS PER IS:2223/IEC:60072

FRAME	FLANGE FIXING						OVER ALL					SHAFT					
	M TOL.	N TOL.	P	S	T	LA	AC	L	AD	D TOL.	E	ED	F TOL.	GD TOL.	G	Y	
KM63	115	95.013/94.991	140	10	3.0	9	123	225	95	11.008/10.997	23	16	4/3.97	4/3.97	8.5/8.4	M4X12	
KM71	130	110.013/109.991	160	10	3.5	10	140	250	110	14.008/13.997	30	22	5/4.97	5/4.97	11.0/10.9	M5X12	

*80 mm MINIMUM DISTANCE TO BE MAINTAINED BY USER FOR EFFECTIVE COOLING.

Dimensional Drawing For TEFC, Face Mounted (B14) Motors: Frames: KM63 & KM71 (Aluminium)

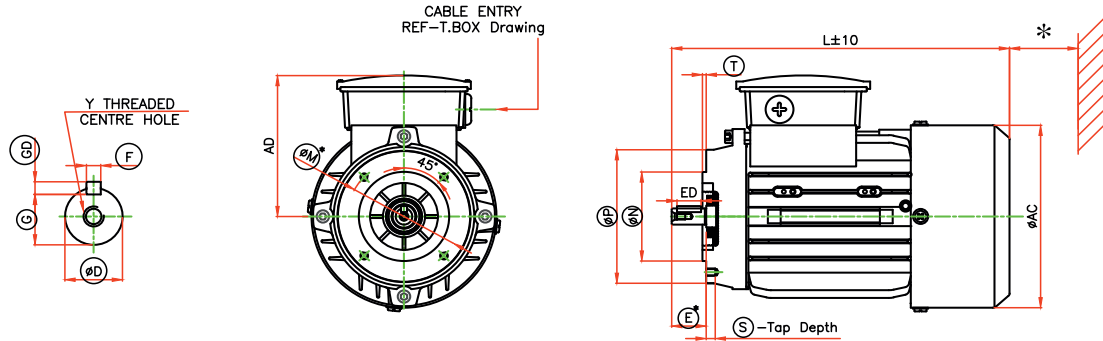

ALL DIMENSIONS ARE IN mm
 RINGED DIMENSIONS ARE AS PER IS:2223/IEC:60072-1
 *TOLERANCES ON MANDATORY DIMENSIONS ARE AS PER IS:2223/IEC:60072

FRAME	FACE FIXING					OVER ALL				SHAFT					
	M TOL.	N TOL.	P	S	T	AC	L	AD	D TOL.	E	ED	F TOL.	GD TOL.	G	Y
KM63	75	60.012/59.993	90	M5X6	2.5	123	225	95	11.008/10.997	23	16	4/3.97	4/3.97	8.5/8.4	M4X12
KM71	85	70.012/69.993	105	M6X8	2.5	140	250	110	14.008/13.997	30	22	5/4.97	5/4.97	11.0/10.9	M5X12

*80 mm MINIMUM DISTANCE TO BE MAINTAINED BY USER FOR EFFECTIVE COOLING.

Dimensional Drawing For TEFC, Foot Mounted (B3) Motors: Frames: KM80 to KM112 (Aluminium)

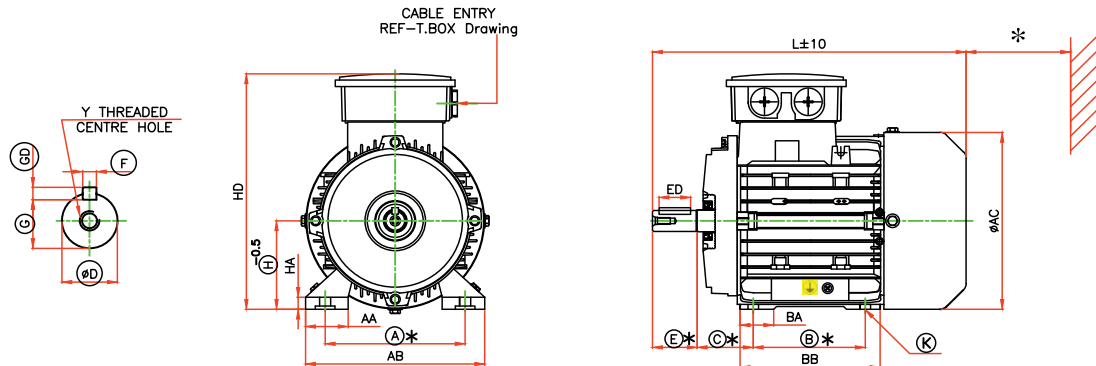

ALL DIMENSIONS ARE IN mm
RINGED DIMENSIONS ARE AS PER IS:1231/IEC:60072-1
*TOLERANCES ON MANDATORY DIMENSIONS ARE AS PER IS:1231/IEC:60072

FRAME	FOOT FIXING									OVER ALL				SHAFT						
	A	B	C	H TOL.	AA	AB	BA	BB	K	AC	L	HD	HA	D TOL.	E	ED	F TOL.	GD TOL.	G	Y
KM80	125	100	50	80/79.5	38	160	30	125	17.5X9.5	160	290	218	11	19.009/18.996	40	28	6/5.97	6/5.97	15.5/15.4	M6X16
KM90S	140	100	56	90/89.5	43	187	30	130	18X12	178	310	227	12.5	24.009/23.996	50	40	8/7.964	7.0/6.9	20.0/19.9	M8X19
KM90L	140	100	56	90/89.5	41	182	31	155	17.5X10	178	332	224	13.5	24.009/23.996	50	40	8/7.964	7.0/6.9	20.0/19.9	M8X19
KM100L	160	140	63	100/99.5	44	194	38	166	18X12.5	198	363	246	11	28.009/27.996	60	50	8/7.964	7.0/6.9	24.0/23.9	M10X24
KM112M	190	140	70	112/111.5	48	225	34	175	20X12	220	395	272	14	28.009/27.996	60	50	8/7.964	7.0/6.9	24.0/23.9	M10X24

Dimensional Drawing For TEFC, Flange Mounted (B5) Motors: Frames: KM80 to KM112 (Aluminium)

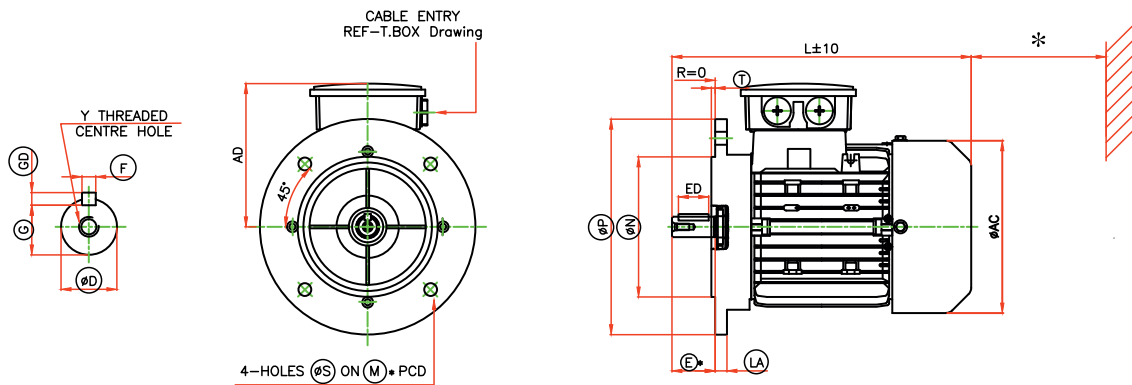

ALL DIMENSIONS ARE IN mm
RINGED DIMENSIONS ARE AS PER IS:2223/IEC:60072-1
*TOLERANCES ON MANDATORY DIMENSIONS ARE AS PER IS:2223/IEC:60072

FRAME	FLANGE FIXING						OVER ALL				SHAFT						
	M TOL.	N TOL.	P	S	T	LA	AC	L	AD	D TOL.	E	ED	F TOL.	GD TOL.	G	Y	
KM80	165	130.014/129.989	200	12	3.5	10	160	278	124	19.009/18.996	40	28	6/5.97	6/5.97	15.5/15.4	M6X16	
KM90S	165	130.014/129.989	200	12	3.5	10	178	316	126	24.009/23.996	50	40	8/7.964	7.0/6.9	20.0/19.9	M8X19	
KM90L	165	130.014/129.989	200	12	4	10	178	332	134	24.009/23.996	50	40	8/7.964	7.0/6.9	20.0/19.9	M8X19	
KM100L	215	180.014/179.989	250	15	4	14	197	364	146	28.009/27.996	60	50	8/7.964	7.0/6.9	24.0/23.9	M10X24	
KM112M	215	180.014/179.989	250	15	4	11	220	380	147	28.009/27.996	60	50	8/7.964	7.0/6.9	24.0/23.9	M10X24	

*80 mm MINIMUM DISTANCE TO BE MAINTAINED BY USER FOR EFFECTIVE COOLING.

Dimensional Drawing For TEFC, Face Mounted (B14) Motors: Frames: KM80 to KM112 (Aluminium)

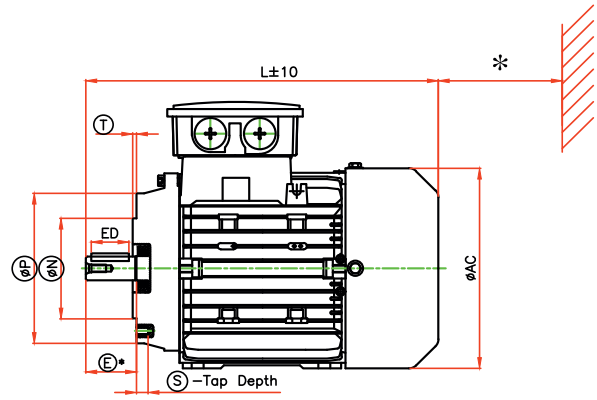
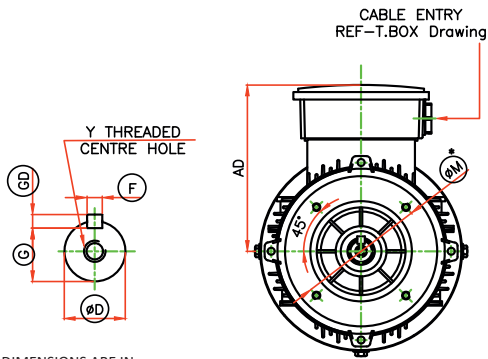

ALL DIMENSIONS ARE IN mm
RINGED DIMENSIONS ARE AS PER IS:2223/IEC:60072-1
*TOLERANCES ON MANDATORY DIMENSIONS ARE AS PER IS:2223/IEC:60072

FRAME	FACE FIXING					OVER ALL			SHAFT						
	M TOL.	N TOL.	P	S	T	AC	L	AD	D TOL.	E	ED	F TOL.	GD TOL.	G	Y
KM80	100	80.012/79.993	120	M6X9	3.0	160	278	133	19.009/18.996	40	28	6/5.97	6/5.97	15.5/15.4	M6X16
KM90S	115	95.013/94.991	140	M8X9	3.0	178	316	126	24.009/23.996	50	40	8/7.964	7.0/6.9	20.0/19.9	M8X19
KM90L	115	95.013/94.991	140	M8X9	3.0	178	332	134	24.009/23.996	50	40	8/7.964	7.0/6.9	20.0/19.9	M8X19
KM100L	130	110.013/109.991	160	M8X9	3.5	198	364	146	28.009/27.996	60	50	8/7.964	7.0/6.9	24.0/23.9	M10X24
KM112M	130	110.013/109.991	160	M8X13	3.5	220	380	160	28.009/27.996	60	50	8/7.964	7.0/6.9	24.0/23.9	M10X24

*80 mm MINIMUM DISTANCE TO BE MAINTAINED BY USER FOR EFFECTIVE COOLING.

Dimensional Drawing For TEFC, Foot Mounted (B3) Motors: Frames: KM80 to KM132 (Cast Iron)

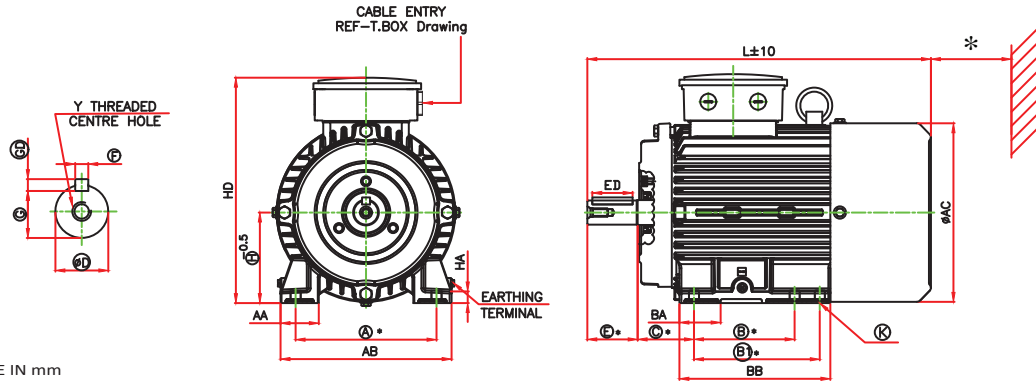

ALL DIMENSIONS ARE IN mm
RINGED DIMENSIONS ARE AS PER IS:1231/IEC:60072-1
*TOLERANCES ON MANDATORY DIMENSIONS ARE AS PER IS:1231/IEC:60072

FRAME	FOOT FIXING										OVER ALL				SHAFT						
	A	B	B1	C	H TOL.	AA	AB	BA	BB	K	AC	L	HD	HA	D TOL.	E	ED	F TOL.	GD TOL.	G	Y
KM80	125	100	--	50	80/79.5	35	152	43	127	10/10.5	156	290	207	11	19.009/18.996	40	28	6/5.97	6/5.97	15.5/15.4	M6X16
KM90S	140	100	125	56	90/89.5	38	170	41	149	10/10.5	178	340	227	11	24.009/23.996	50	40	8/7.964	7.0/6.9	20.0/19.9	M8X19
KM90L	140	100	125	56	90/89.5	38	170	36	160	10/10.5	178	355	227	11	24.009/23.996	50	40	8/7.964	7.0/6.9	20.0/19.9	M8X19
KM100L	160	140	--	63	100/99.5	52	200	58	190	12/12.5	198	410	245	15	28.009/27.996	60	50	8/7.964	7.0/6.9	24.0/23.9	M10X24
KM112M	190	140	--	70	112/111.5	48	220	68	198	12/12.5	220	422	268	15	28.009/27.996	60	50	8/7.964	7.0/6.9	24.0/23.9	M10X24
KM132S	216	140	178	89	132/131.5	52	244	44	221	12/12.5	258	495	305	15	38.018/38.002	80	70	10/9.954	8.0/7.9	33.0/32.9	M12X28
KM132M	216	140	178	89	132/131.5	54	244	60	240	12/12.5	258	520	305	15	38.018/38.002	80	70	10/9.954	8.0/7.9	33.0/32.9	M12X28

Dimensional Drawing For TEFC, Flange Mounted (B5) Motors: Frames: KM80 to KM132 (Cast Iron)

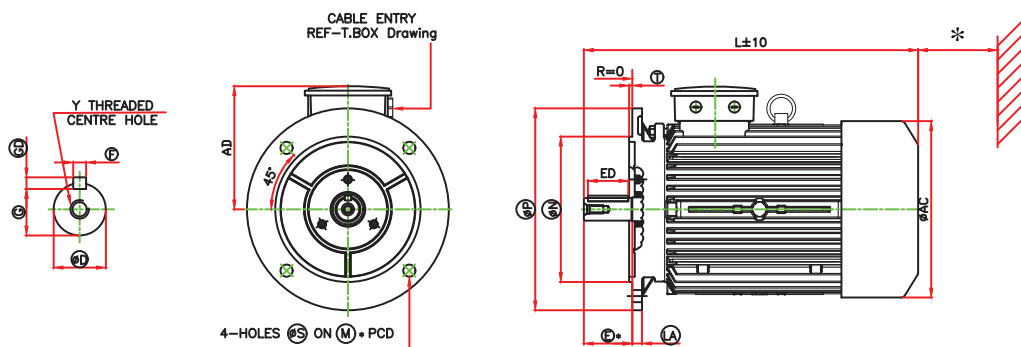

ALL DIMENSIONS ARE IN mm
RINGED DIMENSIONS ARE AS PER IS:2223/IEC:60072-1
*TOLERANCES ON MANDATORY DIMENSIONS ARE AS PER IS:2223/IEC:60072

FRAME	FLANGE FIXING							OVER ALL				SHAFT						
	M TOL.	N TOL.	P	S	T	LA	AC	L	AD	D TOL.	E	ED	F TOL.	GD TOL.	G	Y		
KM80	165	130.014/129.989	200	12	3.5	10	156	290	127	19.009/18.996	40	28	6/5.97	6/5.97	15.5/15.4	M6X16		
KM90S	165	130.014/129.989	200	12	3.5	10	178	340	137	24.009/23.996	50	40	8/7.964	7.0/6.9	20.0/19.9	M8X19		
KM90L	165	130.014/129.989	200	12	3.5	10	178	355	137	24.009/23.996	50	40	8/7.964	7.0/6.9	20.0/19.9	M8X19		
KM100L	215	180.014/179.989	250	15	4	11	198	410	145	28.009/27.996	60	50	8/7.964	7.0/6.9	24.0/23.9	M10X24		
KM112M	215	180.014/179.989	250	15	4	11	220	422	155	28.009/27.996	60	50	8/7.964	7.0/6.9	24.0/23.9	M10X24		
KM132S	265	230.016/229.987	300	15	4	12	258	495	173	38.018/38.002	80	70	10/9.954	8.0/7.9	33.0/32.9	M12X28		
KM132M	265	230.016/229.987	300	15	4	12	258	520	173	38.018/38.002	80	70	10/9.954	8.0/7.9	33.0/32.9	M12X28		

*80 mm MINIMUM DISTANCE TO BE MAINTAINED BY USER FOR EFFECTIVE COOLING.

Dimensional Drawing For TEFC, Foot Cum Flange Mounted (B35) Motors: Frames: KM80 to KM132 (Cast Iron)

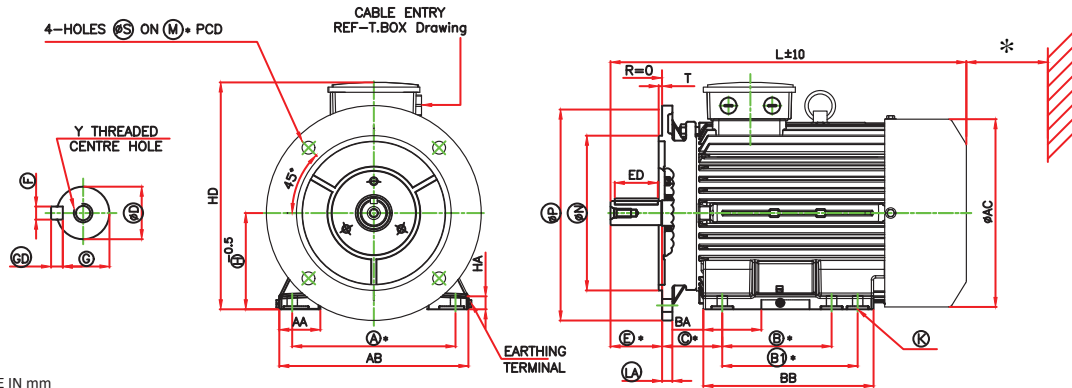

ALL DIMENSIONS ARE IN mm
RINGED DIMENSIONS ARE AS PER IS:1231/IS:2223/IEC:60072-1
*TOLERANCES ON MANDATORY DIMENSIONS ARE AS PER IS:1231/IS:2223/IEC:60072

FRAME	FOOT FIXING										OVER ALL				SHAFT						
	A	B	B1	C	H TOL.	AA	AB	BA	BB	K	AC	L	HD	HA	D TOL.	E	ED	F TOL.	GD TOL.	G	Y
KM80	125	100	—	50	80/79.5	35	152	43	127	10/10.5	156	290	207	11	19.009/18.996	40	28	6/5.97	6/5.97	15.5/15.4	M6X16
KM90S	140	100	125	56	90/89.5	38	170	41	149	10/10.5	178	340	227	11	24.009/23.996	50	40	8/7.964	7.0/6.9	20.0/19.9	M8X19
KM90L	140	100	125	56	90/89.5	38	170	36	160	10/10.5	178	355	227	11	24.009/23.996	50	40	8/7.964	7.0/6.9	20.0/19.9	M8X19
KM100L	160	140	—	63	100/99.5	52	200	58	190	12/12.5	198	410	245	15	28.009/27.996	60	50	8/7.964	7.0/6.9	24.0/23.9	M10X24
KM112M	190	140	—	70	112/111.5	48	220	68	198	12/12.5	220	422	268	15	28.009/27.996	60	50	8/7.964	7.0/6.9	24.0/23.9	M10X24
KM132S	216	140	178	89	132/131.5	52	244	44	221	12/12.5	258	495	305	15	38.018/38.002	80	70	10/9.954	8.0/7.9	33.0/32.9	M12X28
KM132M	216	140	178	89	132/131.5	54	244	60	240	12/12.5	258	520	305	15	38.018/38.002	80	70	10/9.954	8.0/7.9	33.0/32.9	M12X28

FRAME	FLANGE FIXING					
	M TOL.	N TOL.	P	S	T	LA
KM80	165	130.014/129.989	200	12	3.5	10
KM90S	165	130.014/129.989	200	12	3.5	10
KM90L	165	130.014/129.989	200	12	3.5	10
KM100L	215	180.014/179.989	250	15	4	11
KM112M	215	180.014/179.989	250	15	4	11
KM132S	265	230.016/229.987	300	15	4	12
KM132M	265	230.016/229.987	300	15	4	12

*80 mm MINIMUM DISTANCE TO BE MAINTAINED BY USER FOR EFFECTIVE COOLING.

Dimensional Drawing For TEFC, Face Mounted (B14) Motors: Frames: KM80 to KM132 (Cast Iron)

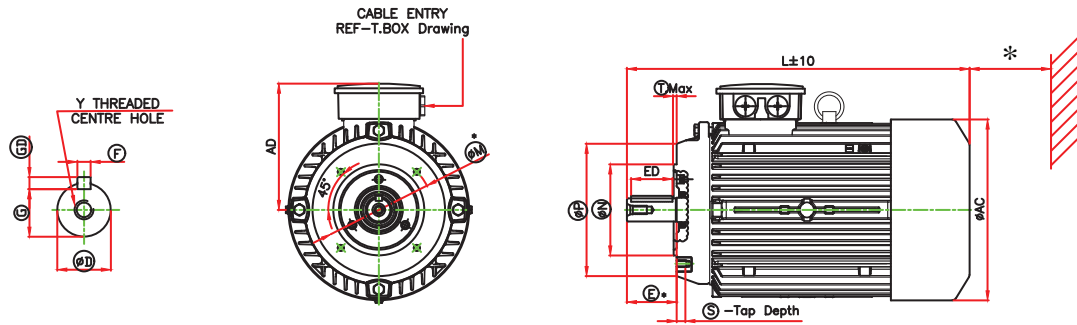

ALL DIMENSIONS ARE IN mm
RINGED DIMENSIONS ARE AS PER IS:2223/IEC:60072-1
*TOLERANCES ON MANDATORY DIMENSIONS ARE AS PER IS:2223/IEC:60072

FRAME	FACE FIXING					OVER ALL			SHAFT						
	M TOL.	N TOL.	P	S	T	AC	L	AD	D TOL.	E	ED	F TOL.	GD TOL.	G	Y
KM80	100	80.012/79.993	120	M6X8	3.0	156	290	127	19.009/18.996	40	28	6/5.97	6/5.97	15.5/15.4	M6X16
KM90S	115	95.013/94.991	140	M8X10	3.0	178	340	137	24.009/23.996	50	40	8/7.964	7.0/6.9	20.0/19.9	M8X19
KM90L	115	95.013/94.991	140	M8X10	3.0	178	355	137	24.009/23.996	50	40	8/7.964	7.0/6.9	20.0/19.9	M8X19
KM100L	130	110.013/109.991	160	M8X10	3.5	198	410	145	28.009/27.996	60	50	8/7.964	7.0/6.9	24.0/23.9	M10X24
KM112M	130	110.013/109.991	160	M8X10	3.5	220	422	155	28.009/27.996	60	50	8/7.964	7.0/6.9	24.0/23.9	M10X24
KM132S	165	130.014/129.989	200	M10X12	3.5	258	495	173	38.018/38.002	80	70	10/9.954	8.0/7.9	33.0/32.9	M12X28
KM132M	165	130.014/129.989	200	M10X12	3.5	258	520	173	38.018/38.002	80	70	10/9.954	8.0/7.9	33.0/32.9	M12X28

*80 mm MINIMUM DISTANCE TO BE MAINTAINED BY USER FOR EFFECTIVE COOLING.

Dimensional Drawing For TEFC, Foot Mounted (B3) Motors: Frames: KM160 to KM200 (Cast Iron)

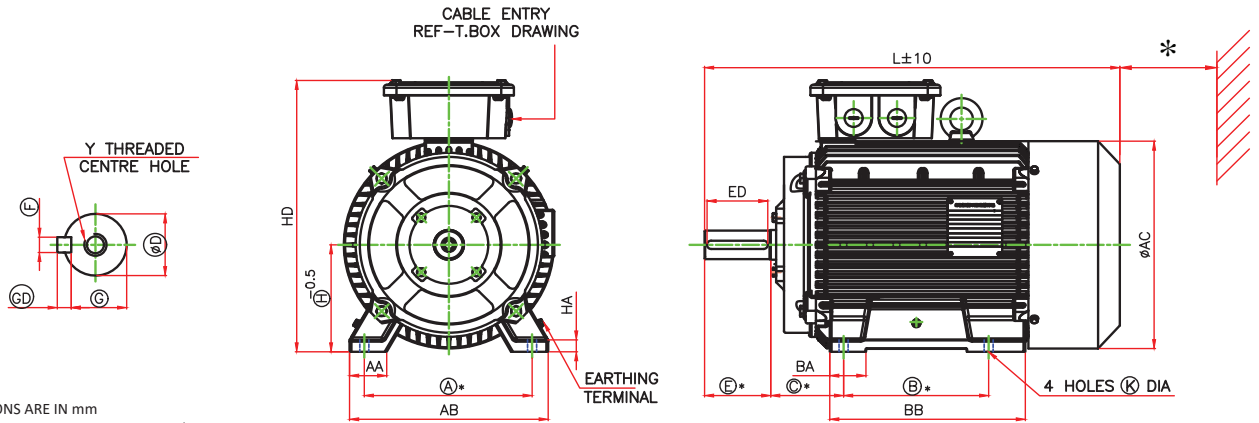

ALL DIMENSIONS ARE IN mm
RINGED DIMENSIONS ARE AS PER IS:1231/IEC:60072-1
*TOLERANCES ON MANDATORY DIMENSIONS ARE AS PER IS:1231/IEC:60072

FRAME	FOOT FIXING									OVER ALL				SHAFT						
	A	B	C	H TOL.	AA	AB	BA	BB	K	AC	L	HD	HA	D TOL.	E	ED	F TOL.	GD TOL.	G	Y
KM160M	254	210	108	160/159.5	60	314	60	266	15/15.5	309	600	382	20	42.018/42.002	110	100	12/11.957	8.0/7.9	37.0/36.9	M16X32
KM160L	254	254	108	160/159.5	60	314	60	309	15/15.5	309	644	382	20	42.018/42.002	110	100	12/11.957	8.0/7.9	37.0/36.9	M16X32
KM180M	279	241	121	180/179.5	62	330	97	325	15/15.5	349	690	457	20	48.018/48.002	110	100	14/13.957	9.0/8.9	42.5/42.4	M16X32
KM180L	279	279	121	180/179.5	62	330	97	325	15/15.5	349	690	457	20	48.018/48.002	110	100	14/13.957	9.0/8.9	42.5/42.4	M16X32
KM200L	318	305	133	200/199.5	87	390	71	368	19/19.5	384	750	497	24	55.030/55.011	110	100	16/15.957	10.0/9.9	49.0/48.9	M20X40

Dimensional Drawing For TEFC, Flange Mounted (B5) Motors: Frames: KM160 to KM200 (Cast Iron)

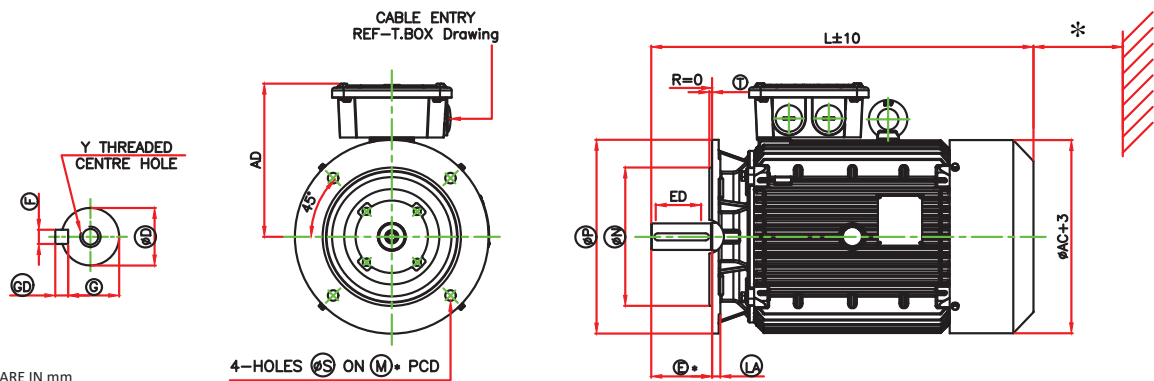

ALL DIMENSIONS ARE IN mm
RINGED DIMENSIONS ARE AS PER IS:2223/IEC:60072-1
*TOLERANCES ON MANDATORY DIMENSIONS ARE AS PER IS:2223/IEC:60072

FRAME	FLANGE FIXING						OVER ALL				SHAFT						
	M TOL.	N TOL.	P	S	T	LA	AC	L	AD	D TOL.	E	ED	F TOL.	GD TOL.	G	Y	
KM160M	300	250.016/249.987	350	19	5	13	309	600	212	42.018/42.002	110	100	12/11.957	8.0/7.9	37.0/36.9	M16X32	
KM160L	300	250.016/249.987	350	19	5	13	309	644	212	42.018/42.002	110	100	12/11.957	8.0/7.9	37.0/36.9	M16X32	
KM180M/L	300	250.016/249.987	350	19	5	15	349	690	277	48.018/48.002	110	100	14/13.957	9.0/8.9	42.5/42.4	M16X32	
KM200L	350	300.016/299.987	400	19	5	20	384	750	297	55.030/55.011	110	100	16/15.957	10.0/9.9	49.0/48.9	M20X40	

*100 mm MINIMUM DISTANCE TO BE MAINTAINED BY USER FOR EFFECTIVE COOLING.

Dimensional Drawing For TEFC, Foot Cum Flange Mounted (B35) Motors: Frames: KM160 to KM200 (Cast Iron)

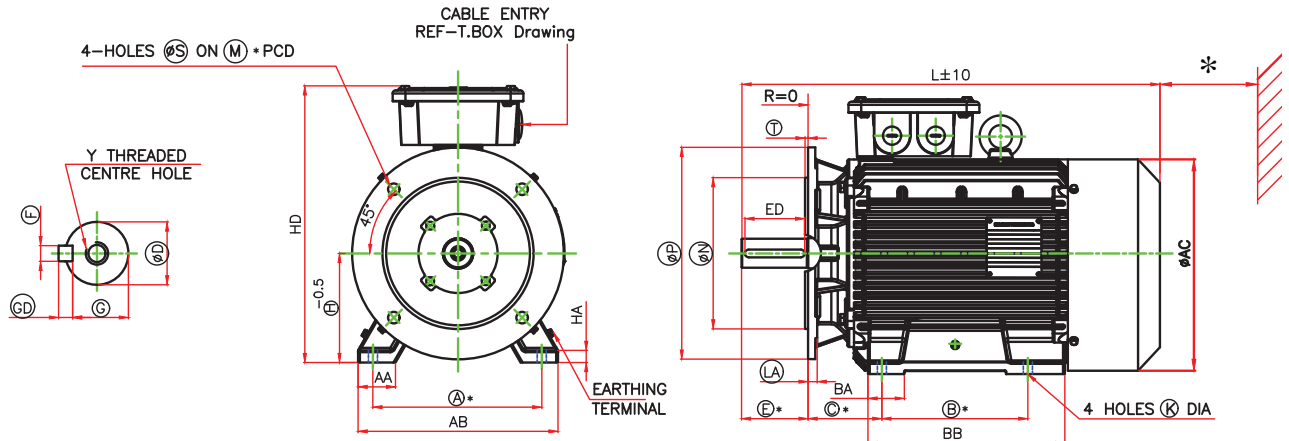

ALL DIMENSIONS ARE IN mm
RINGED DIMENSIONS ARE AS PER IS:1231/IS:2223/IEC:60072-1
*TOLERANCES ON MANDATORY DIMENSIONS ARE AS PER IS:1231/IS:2223/IEC:60072

FRAME	FOOT FIXING									OVER ALL				SHAFT						
	A	B	C	H TOL.	AA	AB	BA	BB	K	AC	L	HD	HA	D TOL.	E	ED	F TOL.	GD TOL.	G	Y
KM160M	254	210	108	160/159.5	60	314	60	266	15/15.5	309	600	382	20	42.018/42.002	110	100	12/11.957	8.0/7.9	37.0/36.9	M16X32
KM160L	254	254	108	160/159.5	60	314	60	309	15/15.5	309	644	382	20	42.018/42.002	110	100	12/11.957	8.0/7.9	37.0/36.9	M16X32
KM180M	279	241	121	180/179.5	62	330	97	325	15/15.5	349	690	457	20	48.018/48.002	110	100	14/13.957	9.0/8.9	42.5/42.4	M16X32
KM180L	279	279	121	180/179.5	62	330	97	325	15/15.5	349	690	457	20	48.018/48.002	110	100	14/13.957	9.0/8.9	42.5/42.4	M16X32
KM200L	318	305	133	200/199.5	87	390	71	368	19/19.5	384	750	497	24	55.030/55.011	110	100	16/15.957	10.0/9.9	49.0/48.9	M20X40

FRAME	FLANGE FIXING					
	M TOL.	N TOL.	P	S	T	LA
KM160M	300	250.016/249.987	350	19	5	13
KM160L	300	250.016/249.987	350	19	5	13
KM180M/L	300	250.016/249.987	350	19	5	15
KM200L	350	300.016/299.987	400	19	5	20

*100 mm MINIMUM DISTANCE TO BE MAINTAINED BY USER FOR EFFECTIVE COOLING.

Dimensional Drawing For TEFC, Foot Mounted (B3) Motors: Frames: KM225 to KM280 (Cast Iron)

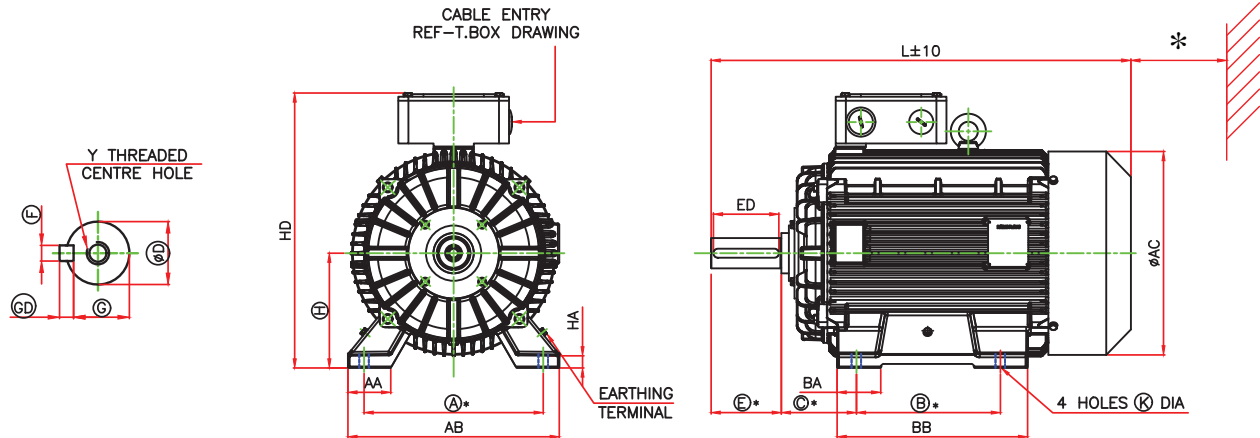

ALL DIMENSIONS ARE IN mm
RINGED DIMENSIONS ARE AS PER IS:1231/IEC:60072-1
*TOLERANCES ON MANDATORY DIMENSIONS ARE AS PER IS:1231/IEC:60072

POLE: 2

FRAME	FOOT FIXING										OVER ALL				SHAFT					
	A	B	C	H TOL.	AA	AB	BA	BB	K	AC	L	HD	HA	D TOL.	E	ED	F TOL.	GD TOL.	G	Y
KM225M	356	311	149	225/224.5	87	420	106	377	19/19.5	405	820	550	24	55.030/55.011	110	100	16/15.957	10.0/9.9	49.0/48.9	M20X40
KM250M	406	349	168	250/249.5	92	498	90	434	24/24.5	454	920	600	25	60.030/60.011	140	130	18/17.957	11.0/10.9	53.0/52.9	M20X40
KM280S	457	368	190	280/279	112	540	140	500	24/24.5	560	1050	730	37	65.030/65.011	140	130	18/17.957	11.0/10.9	58.0/57.9	M20X40
KM280M	457	419	190	280/279	112	540	140	500	24/24.5	560	1050	730	37	65.030/65.011	140	130	18/17.957	11.0/10.9	58.0/57.9	M20X40

POLE: 4

FRAME	FOOT FIXING										OVER ALL				SHAFT					
	A	B	C	H TOL.	AA	AB	BA	BB	K	AC	L	HD	HA	D TOL.	E	ED	F TOL.	GD TOL.	G	Y
KM225S	356	286	149	225/224.5	87	420	106	377	19/19.5	405	850	550	24	60.030/60.011	140	130	18/17.957	11.0/10.9	53.0/52.9	M20X40
KM225M	356	311	149	225/224.5	87	420	106	377	19/19.5	405	850	550	24	60.030/60.011	140	130	18/17.957	11.0/10.9	53.0/52.9	M20X40
KM250M	406	349	168	250/249.5	92	498	90	434	24/24.5	454	920	600	25	65.030/65.011	140	130	18/17.957	11.0/10.9	58.0/57.9	M20X40
KM280S	457	368	190	280/279	112	540	140	500	24/24.5	560	1050	730	37	75.030/75.011	140	130	20/19.948	12.0/11.9	67.5/67.4	M20X40
KM280M	457	419	190	280/279	112	540	140	500	24/24.5	560	1050	730	37	75.030/75.011	140	130	20/19.948	12.0/11.9	67.5/67.4	M20X40

*100 mm MINIMUM DISTANCE TO BE MAINTAINED BY USER FOR EFFECTIVE COOLING.

Dimensional Drawing For TEFC, Flange Mounted (B5) Motors: Frames: KM225 to KM280 (Cast Iron)

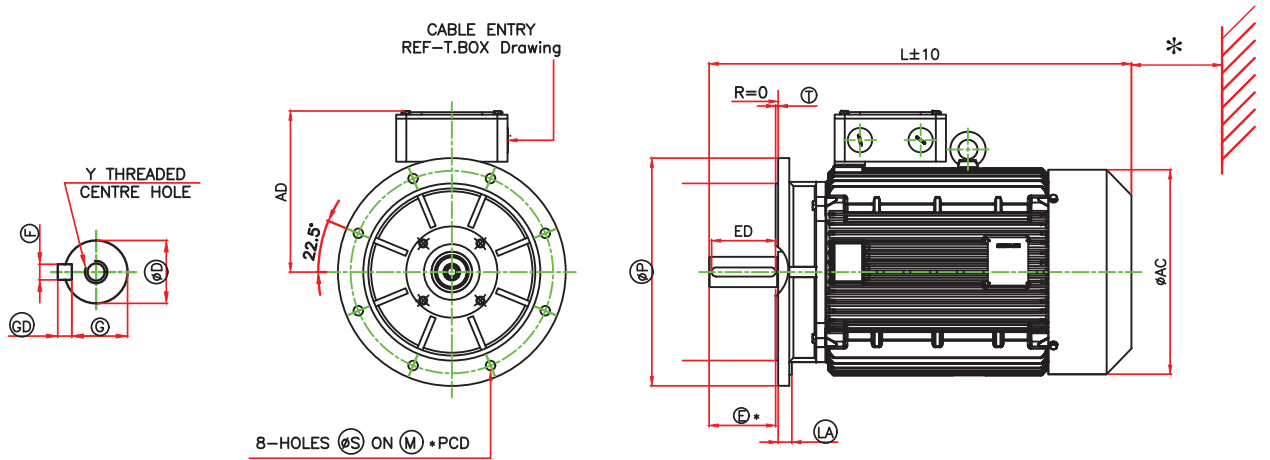

ALL DIMENSIONS ARE IN mm
RINGED DIMENSIONS ARE AS PER IS:2223/IEC:60072-1
*TOLERANCES ON MANDATORY DIMENSIONS ARE AS PER IS:2223/IEC:60072

POLE: 2

FRAME	FLANGE FIXING						OVER ALL			SHAFT						
	M TOL.	N TOL.	P	S	T	LA	AC	L	AD	D TOL.	E	ED	F TOL.	GD TOL.	G	Y
KM225M	400	350.018/349.982	450	19	5	22	405	820	325	55.030/55.011	110	100	16/15.957	10.0/9.9	49.0/48.9	M20X40
KM250M	500	450.020/449.980	550	19	5	25	454	920	350	60.030/60.011	140	130	18/17.957	11.0/10.9	53.0/52.9	M20X40
KM280S	500	450.020/449.980	550	19	5	25	560	1050	450	65.030/65.011	140	130	18/17.957	11.0/10.9	58.0/57.9	M20X40
KM280M	500	450.020/449.980	550	19	5	25	560	1050	450	65.030/65.011	140	130	18/17.957	11.0/10.9	58.0/57.9	M20X40

POLE: 4

FRAME	FLANGE FIXING						OVER ALL			SHAFT						
	M TOL.	N TOL.	P	S	T	LA	AC	L	AD	D TOL.	E	ED	F TOL.	GD TOL.	G	Y
KM225S	400	350.018/349.982	450	19	5	22	405	850	325	60.030/60.011	140	130	18/17.957	11.0/10.9	53.0/52.9	M20X40
KM225M	400	350.018/349.982	450	19	5	22	405	850	325	60.030/60.011	140	130	18/17.957	11.0/10.9	53.0/52.9	M20X40
KM250M	500	450.020/449.980	550	19	5	25	454	920	350	65.030/65.011	140	130	18/17.957	11.0/10.9	58.0/57.9	M20X40
KM280S	500	450.020/449.980	550	19	5	25	560	1050	450	75.030/75.011	140	130	20/19.948	12.0/11.9	67.5/67.4	M20X40
KM280M	500	450.020/449.980	550	19	5	25	560	1050	450	75.030/75.011	140	130	20/19.948	12.0/11.9	67.5/67.4	M20X40

*100 mm MINIMUM DISTANCE TO BE MAINTAINED BY USER FOR EFFECTIVE COOLING.

Dimensional Drawing For TEFC, Foot Cum Flange Mounted (B35) Motors: Frames: KM225 to KM280 (Cast Iron)

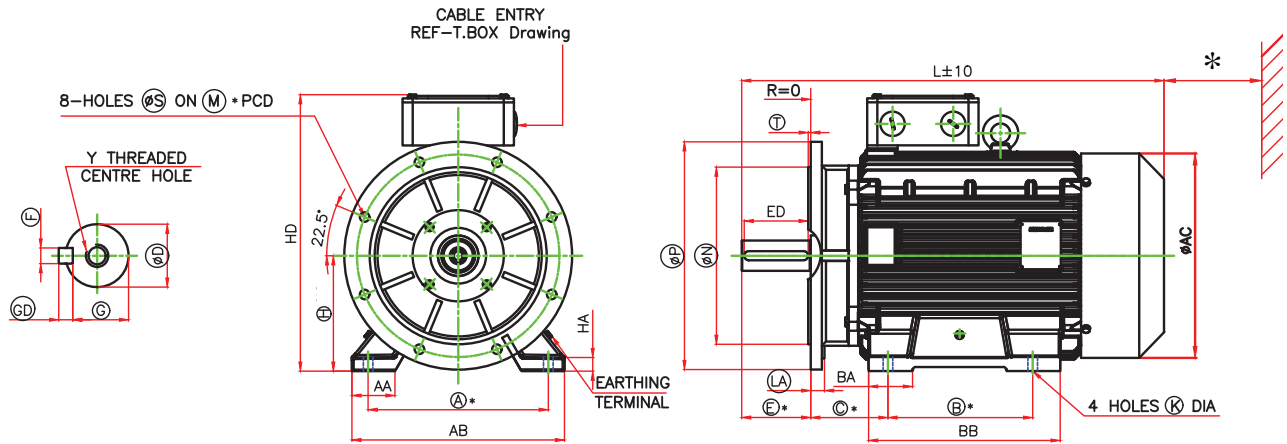

ALL DIMENSIONS ARE IN mm
RINGED DIMENSIONS ARE AS PER IS:1231/IS:2223/IEC:60072-1
*TOLERANCES ON MANDATORY DIMENSIONS ARE AS PER IS:1231/IS:2223/IEC:60072

POLE: 2

FRAME	FOOT FIXING									OVER ALL				SHAFT						
	A	B	C	H TOL.	AA	AB	BA	BB	K	AC	L	HD	HA	D TOL.	E	ED	F TOL.	GD TOL.	G	Y
KM225M	356	311	149	225/224.5	87	420	106	377	19/19.5	405	820	550	24	55.030/55.011	110	100	16/15.957	10.0/9.9	49.0/48.9	M20X40
KM250M	406	349	168	250/249.5	92	498	90	434	24/24.5	454	920	600	25	60.030/60.011	140	130	18/17.957	11.0/10.9	53.0/52.9	M20X40
KM280S	457	368	190	280/279	112	540	140	500	24/24.5	560	1050	730	37	65.030/65.011	140	130	18/17.957	11.0/10.9	58.0/57.9	M20X40
KM280M	457	419	190	280/279	112	540	140	500	24/24.5	560	1050	730	37	65.030/65.011	140	130	18/17.957	11.0/10.9	58.0/57.9	M20X40

FRAME	FLANGE FIXING					
	M TOL.	N TOL.	P	S	T	LA
KM225M	400	350.018/349.982	450	19	5	22
KM250M	500	450.020/449.980	550	19	5	25
KM280S	500	450.020/449.980	550	19	5	25
KM280M	500	450.020/449.980	550	19	5	25

POLE: 4

FRAME	FOOT FIXING									OVER ALL				SHAFT						
	A	B	C	H TOL.	AA	AB	BA	BB	K	AC	L	HD	HA	D TOL.	E	ED	F TOL.	GD TOL.	G	Y
KM225S	356	286	149	225/224.5	87	420	106	377	19/19.5	405	850	550	24	60.030/60.011	140	130	18/17.957	11.0/10.9	53.0/52.9	M20X40
KM225M	356	311	149	225/224.5	87	420	106	377	19/19.5	405	850	550	24	60.030/60.011	140	130	18/17.957	11.0/10.9	53.0/52.9	M20X40
KM250M	406	349	168	250/249.5	92	498	90	434	24/24.5	454	920	600	25	65.030/65.011	140	130	18/17.957	11.0/10.9	58.0/57.9	M20X40
KM280S	457	368	190	280/279	112	540	140	500	24/24.5	560	1050	730	37	75.030/75.011	140	130	20/19.948	12.0/11.9	67.5/67.4	M20X40
KM280M	457	419	190	280/279	112	540	140	500	24/24.5	560	1050	730	37	75.030/75.011	140	130	20/19.948	12.0/11.9	67.5/67.4	M20X40

FRAME	FLANGE FIXING					
	M TOL.	N TOL.	P	S	T	LA
KM225S	400	350.018/349.982	450	19	5	22
KM225M	400	350.018/349.982	450	19	5	22
KM250M	500	450.020/449.980	550	19	5	25
KM280S	500	450.020/449.980	550	19	5	25
KM280M	500	450.020/449.980	550	19	5	25

*100 mm MINIMUM DISTANCE TO BE MAINTAINED BY USER FOR EFFECTIVE COOLING.

Terminal Box Arrangement: Frames: KM63 & KM71

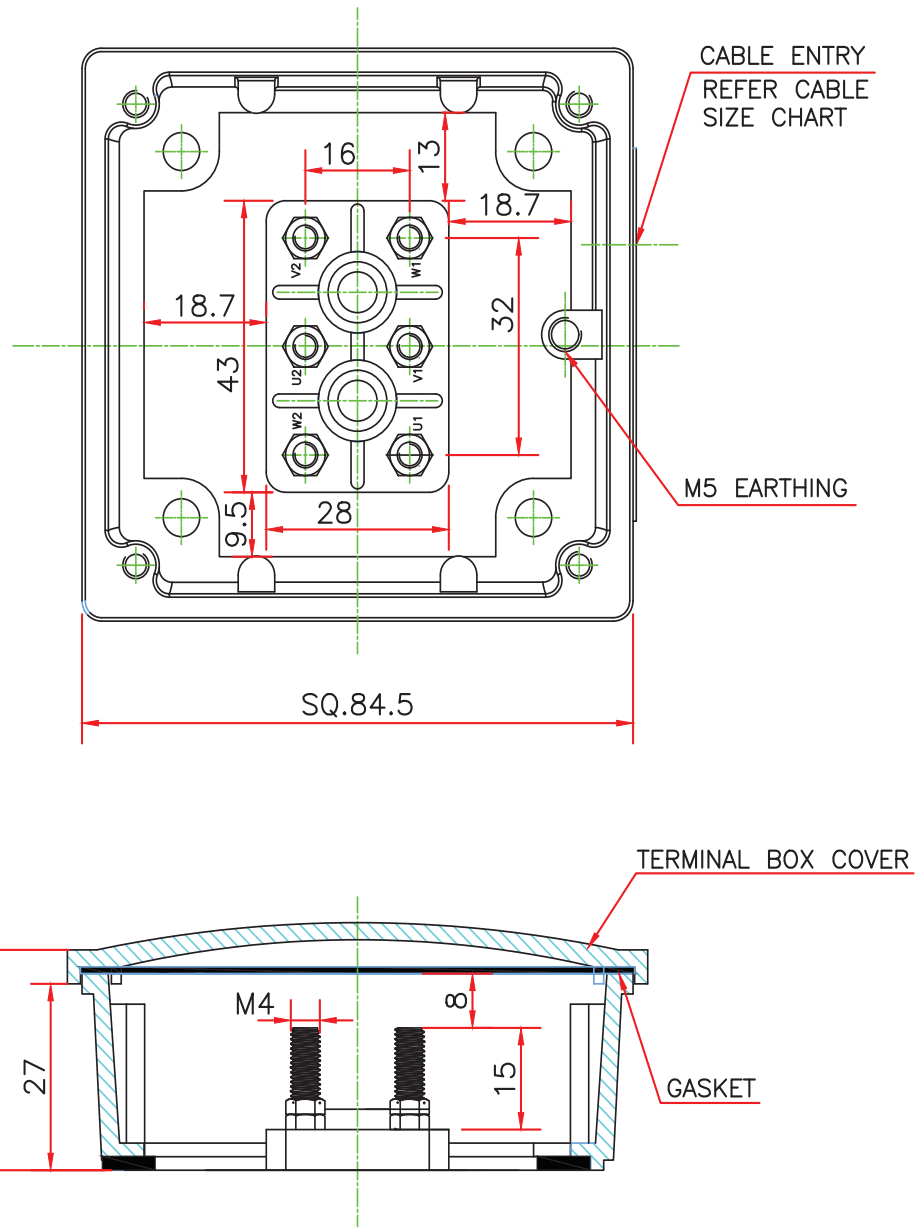

NOTES:

- * TERMINAL BOX CAN BE ROTATED IN 360° IN STEPS OF 90°.
- * ONE EARTHING TERMINAL IS PROVIDED INSIDE THE MAIN TERMINAL BOX.
- * CABLE GLANDS ARE NOT IN KIRLOSKAR SCOPE OF SUPPLY.

Terminal Box Arrangement: Frames: KM80 to KM132

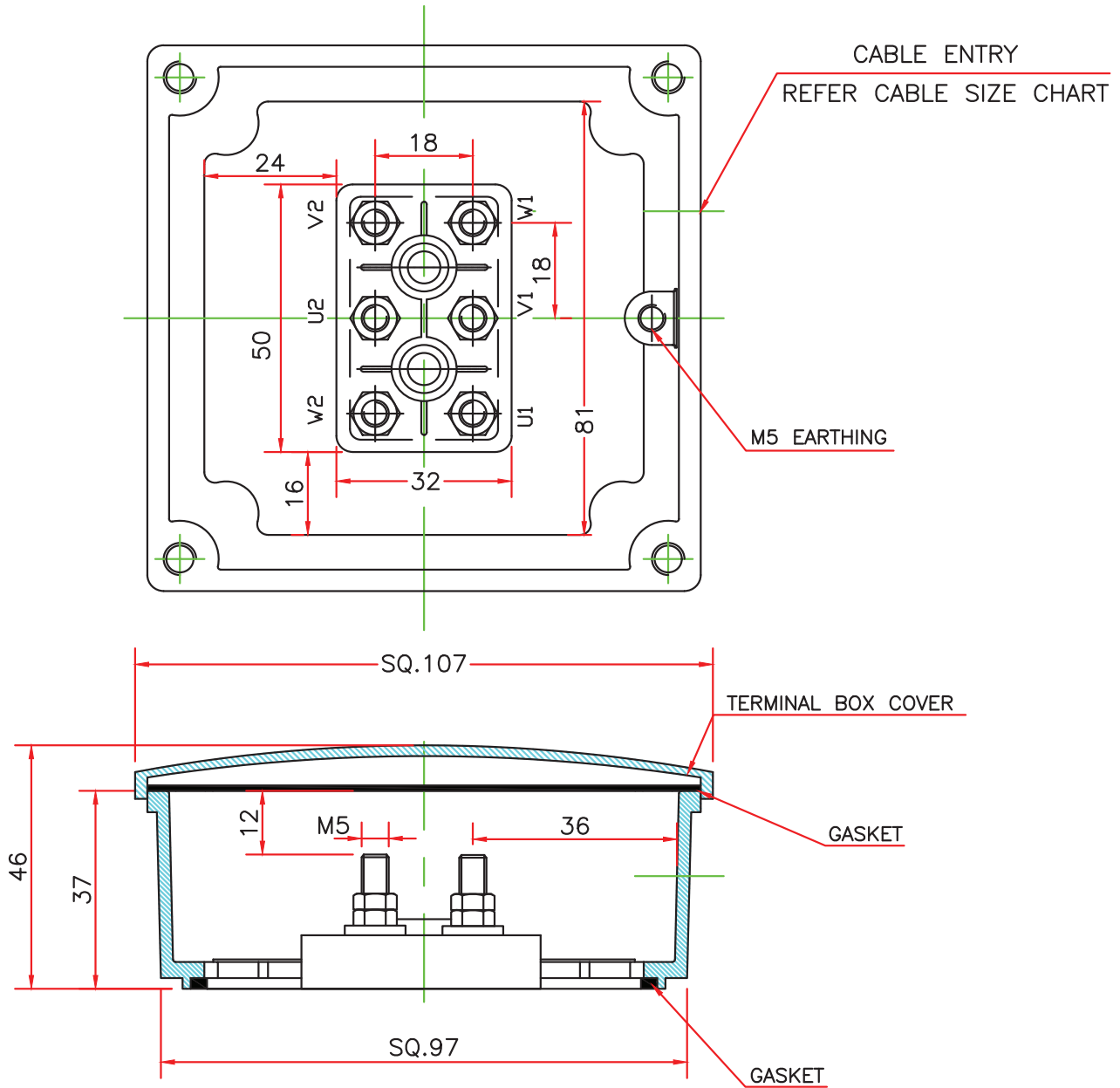

NOTES:

- * TERMINAL BOX CAN BE ROTATED IN 360° IN STEPS OF 90°.
- * ONE EARTHING TERMINAL IS PROVIDED INSIDE THE MAIN TERMINAL BOX.
- * CABLE GLANDS ARE NOT IN KIRLOSKAR SCOPE OF SUPPLY.

Terminal Box Arrangement: Frames: KM160

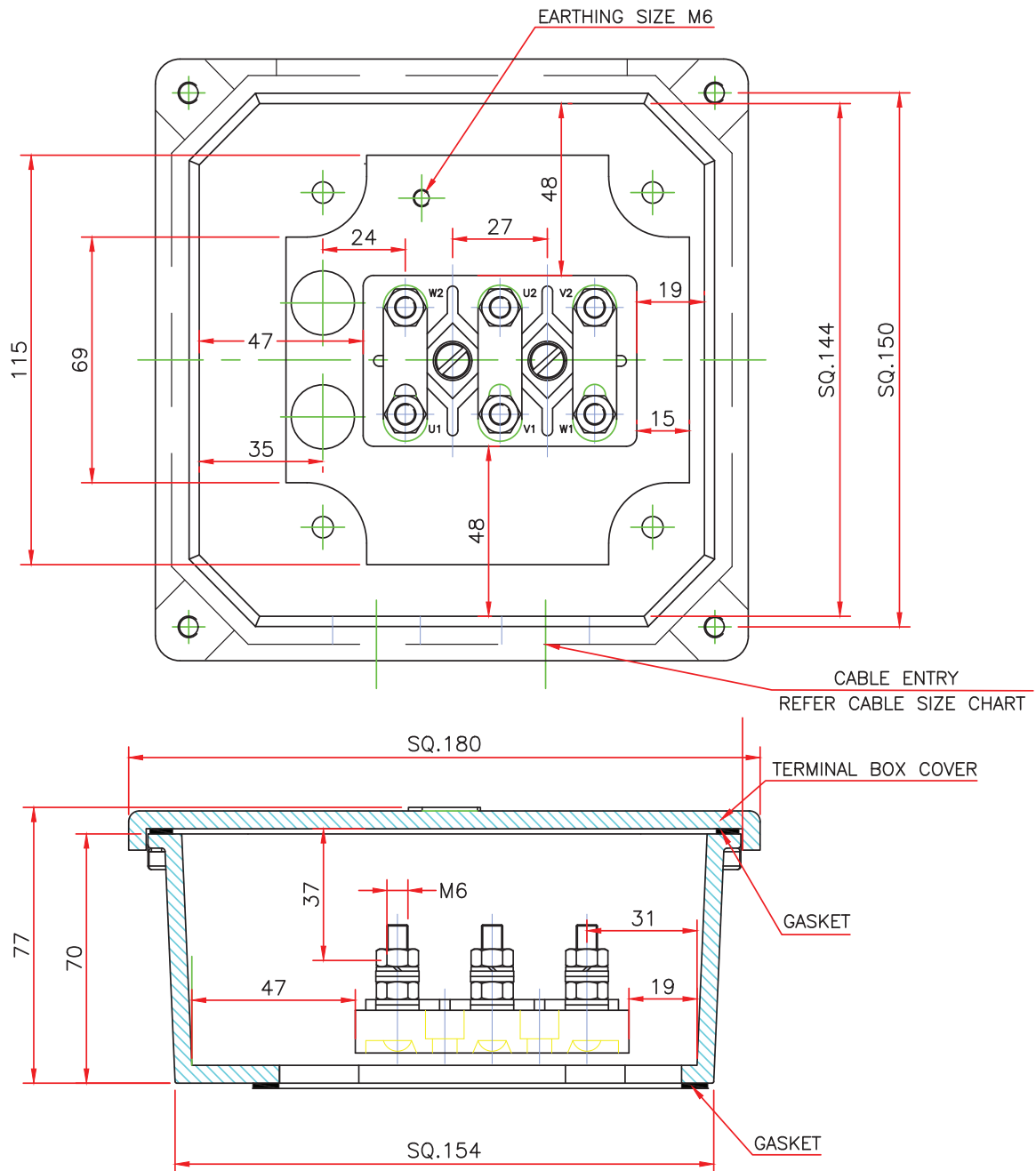

NOTES:

- * TERMINAL BOX CAN BE ROTATED IN 360° IN STEPS OF 90°.
- * ONE EARTHING TERMINAL IS PROVIDED INSIDE THE MAIN TERMINAL BOX.
- * CABLE GLANDS ARE NOT IN KIRLOSKAR SCOPE OF SUPPLY.

Terminal Box Arrangement: Frames: KM180 & KM200

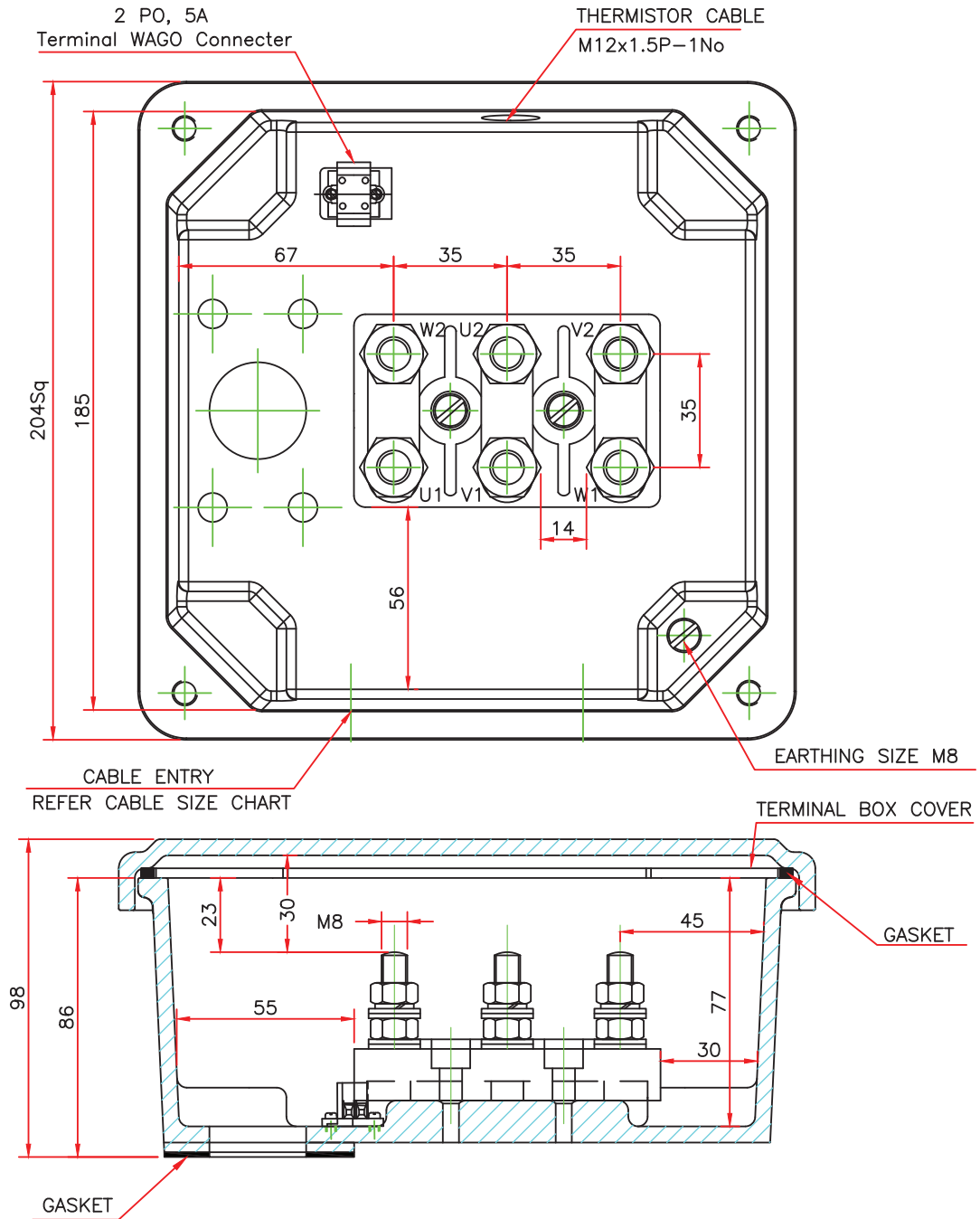

NOTES:

- * MOTORS IN FRAMES KM180-KM200 ARE PROVIDED WITH 3 NO. PTC 130 AS A STANDARD FEATURE.
- * TERMINAL BOX CAN BE ROTATED IN 360° IN STEPS OF 90°.
- * ONE EARTHING TERMINAL IS PROVIDED INSIDE THE MAIN TERMINAL BOX.
- * CABLE GLANDS ARE NOT IN KIRLOSKAR SCOPE OF SUPPLY.

Terminal Box Arrangement: Frames: KM225 & KM250

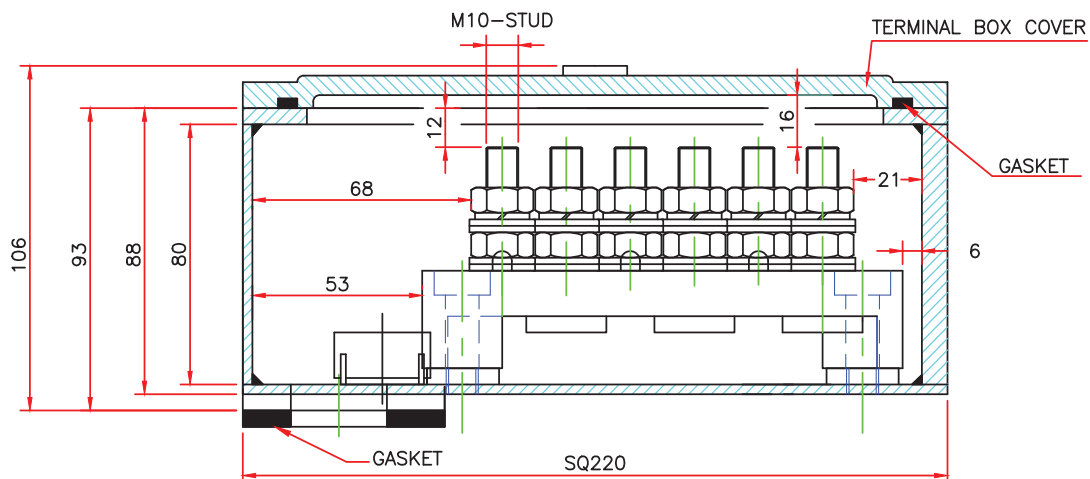
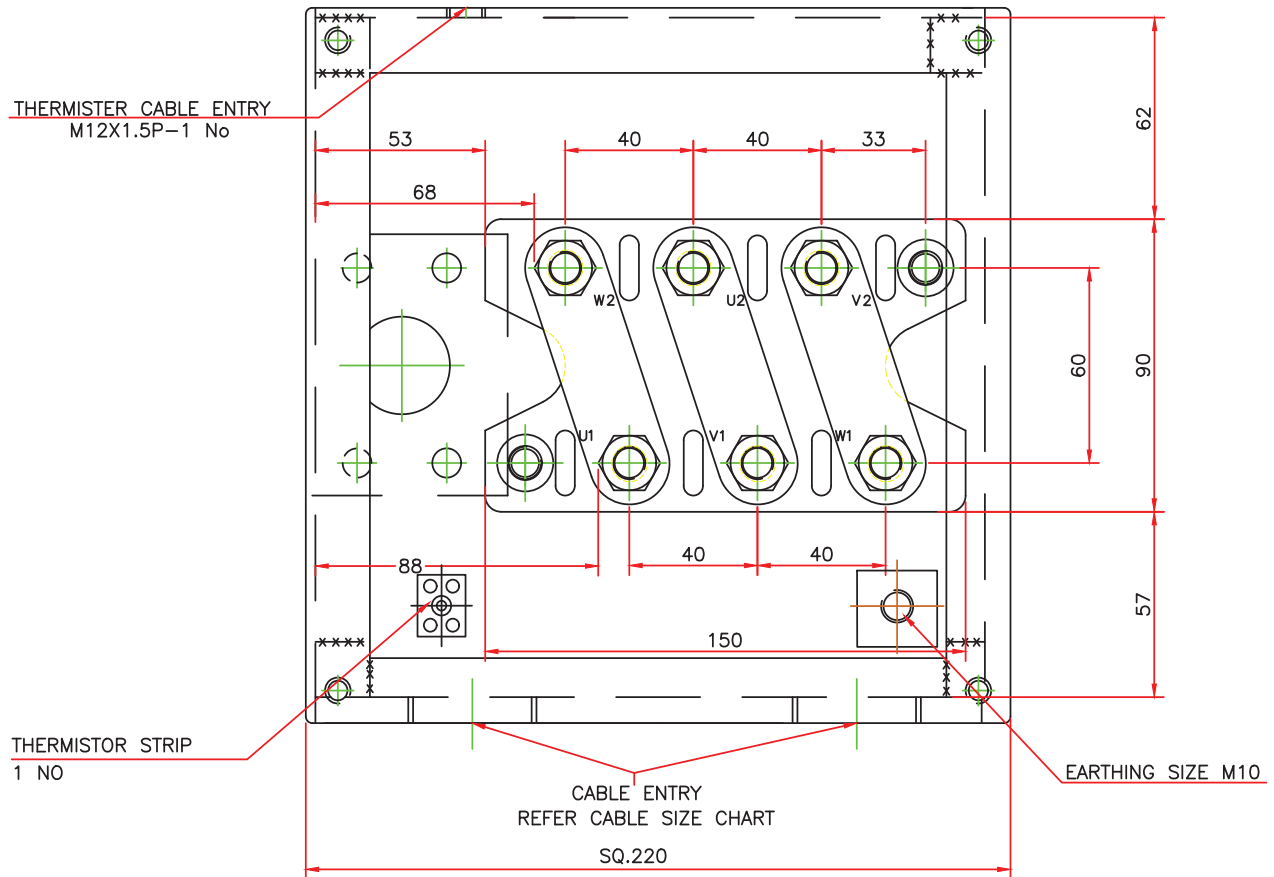

NOTES:

- * MOTORS IN FRAMES KM225-KM250 ARE PROVIDED WITH 3 NO. PTC 130 AS A STANDARD FEATURE.
- * TERMINAL BOX CAN BE ROTATED IN 360° IN STEPS OF 90°.
- * ONE EARTHING TERMINAL IS PROVIDED INSIDE THE MAIN TERMINAL BOX.
- * CABLE GLANDS ARE NOT IN KIRLOSKAR SCOPE OF SUPPLY.

Terminal Box Arrangement: Frames: KM280

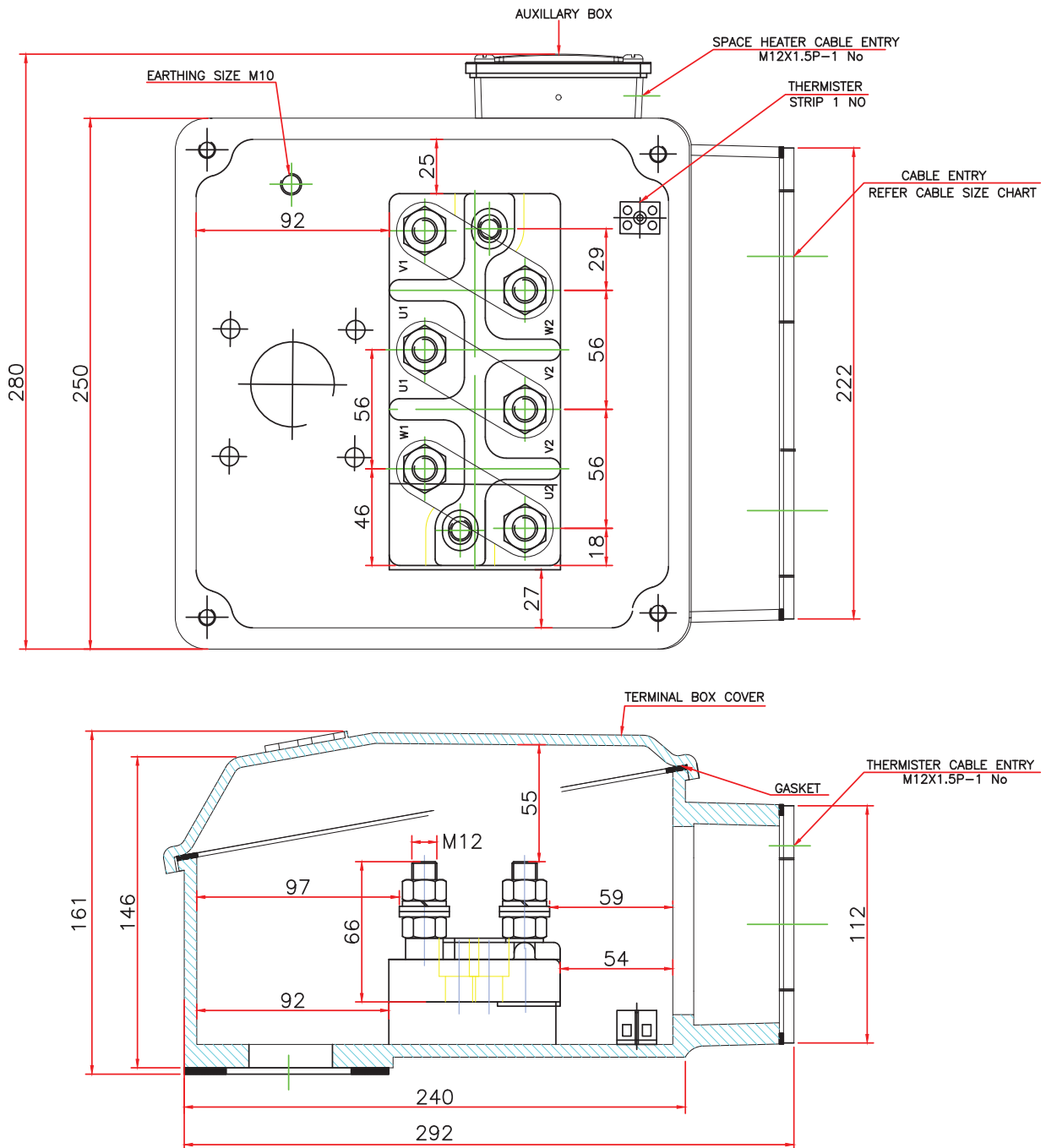

NOTES:

- * MOTORS IN FRAMES KM280 ARE PROVIDED WITH 3 NO. PTC 130 & SPACE HEATER AS A STANDARD FEATURE.
- * TERMINAL BOX CAN BE ROTATED IN 360° IN STEPS OF 90°.
- * ONE EARTHING TERMINAL IS PROVIDED INSIDE THE MAIN TERMINAL BOX.
- * CABLE GLANDS ARE NOT IN KIRLOSKAR SCOPE OF SUPPLY.

Exploded View:

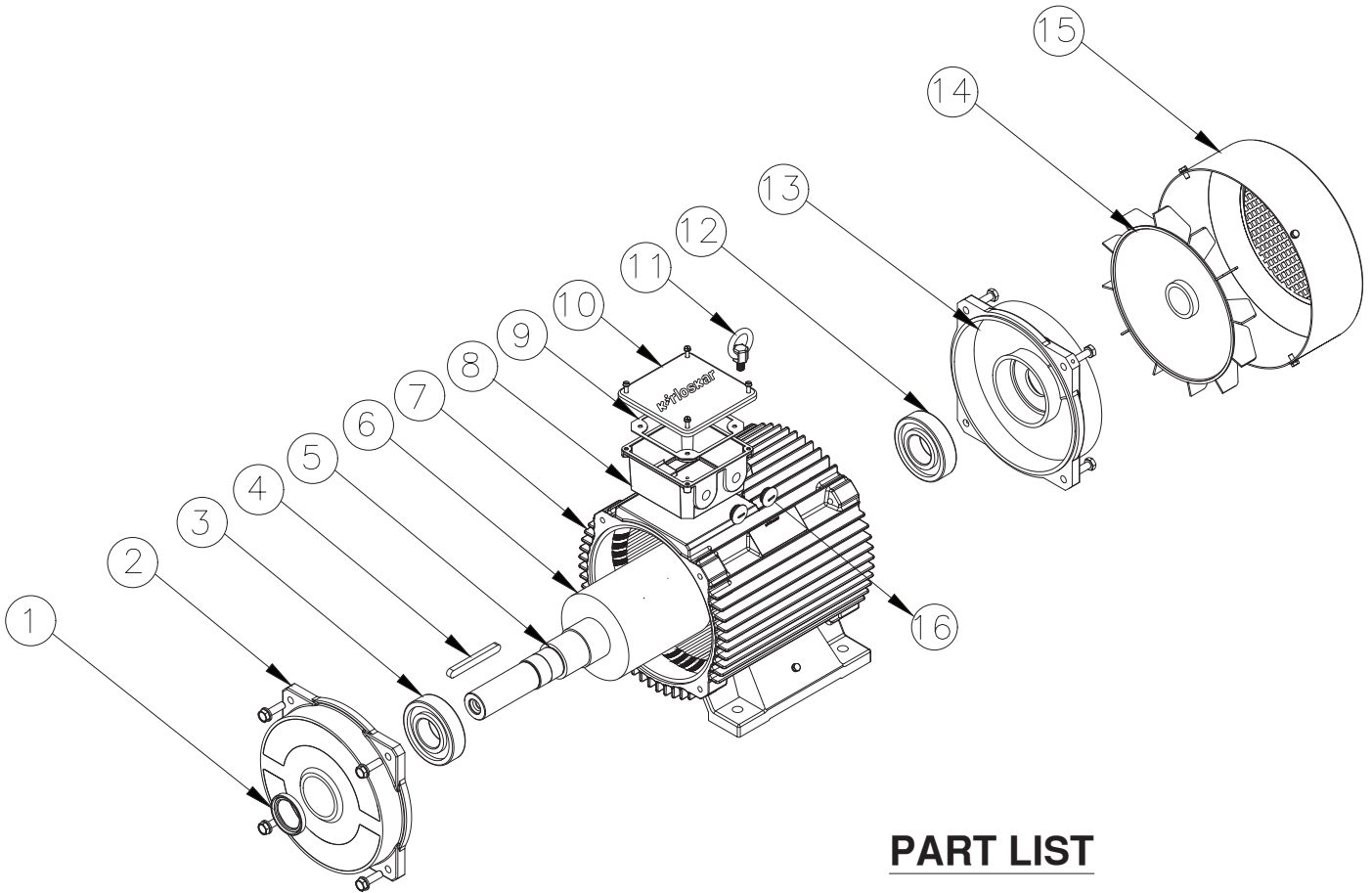

PART LIST

S.No	Part Description	S.No	Part Description
1.	Oil Seal	9.	Rubber Gasket
2.	DE Endshield	10.	Terminal Box Cover
3.	DE Bearing	11.	Eye Bolt
4.	Key	12.	NDE Bearing
5.	Shaft	13.	NDE Endshield
6.	Rotor	14.	Cooling Fan
7.	Body	15.	Fan Cover
8.	Terminal Box	16.	Closing Plug

Product Code Guide:

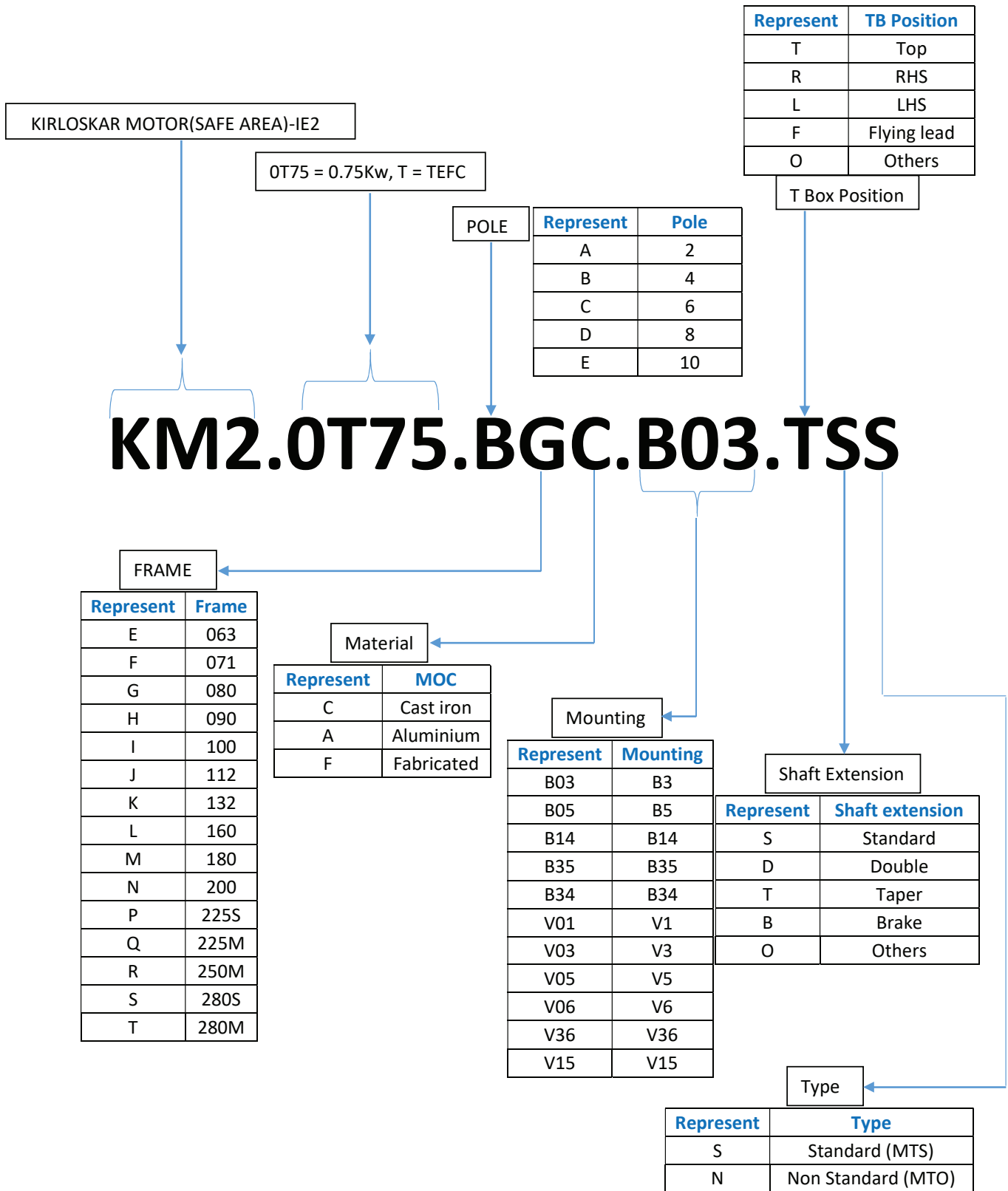

*For other mounting arrangements, please get in touch with KOEL.

Notes:

A series of horizontal dotted lines spanning the width of the page, intended for writing notes.



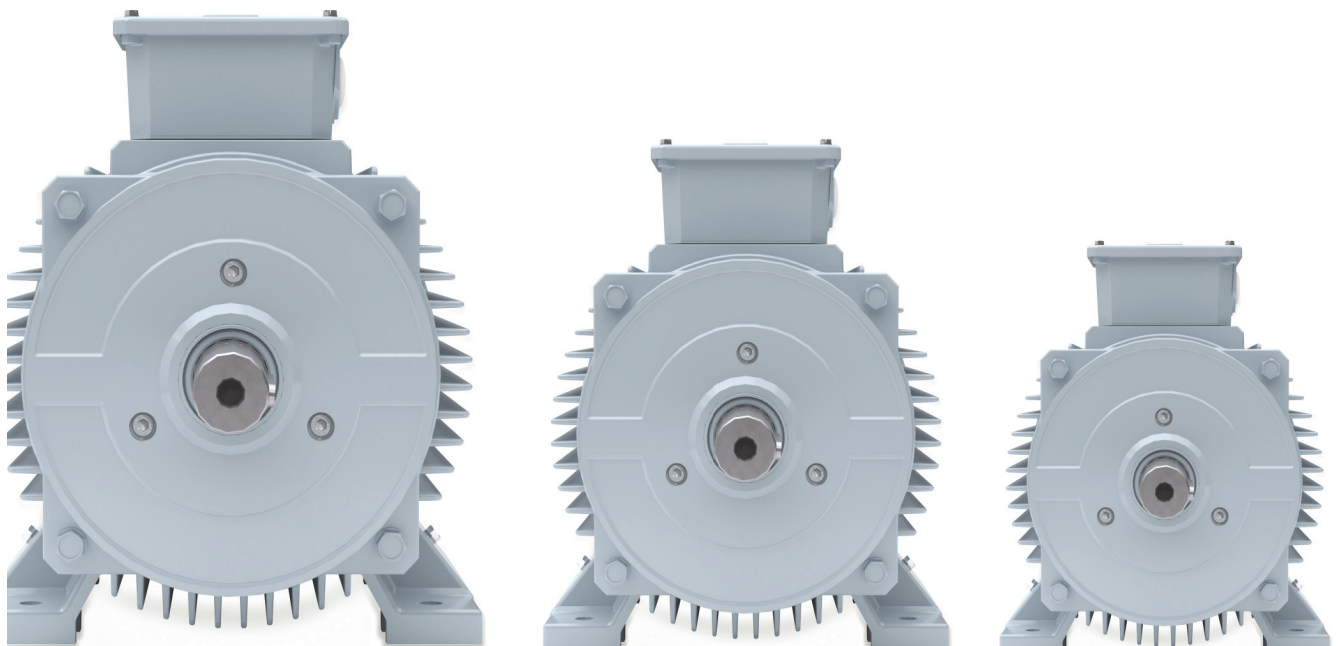

For more information, please contact us at “head.motors@kirloskar.com”

Oil Engines



www.kirloskaroilengines.com

KIRLOSKAR OIL ENGINES LIMITED

A Kirloskar Group Company

Laxmanrao Kirloskar Road, Khadki,
Pune 411 003 INDIA.

 **960 411 4411 / 960 411 8811**

Stamp of
Authorised
Representative

LV-3 PHM / 005 / May 2023